



INTERNATIONAL
MARITIME RESCUE



Basic Rescue Boat Operator Manual

JULY 2022

DEVELOPED FOR LOW-RESOURCE AREAS

About this manual

The primary aim of the *Basic Rescue Boat Operator Manual* is to save lives by providing a resource containing essential skills, knowledge and guidance for those operating in a maritime environment.

This manual is designed for organisations based in areas with limited access to equipment.

This manual has been designed as a guidance document and can be adapted to suit the local environment.

This manual will be reviewed after 3 years. Please send any comments and feedback to: info@imrf.org.uk

JULY 2022

Developed by the IMRF working group comprised of representatives from:



- Ocean Fisheries Ministry, Morocco



- DGzRS, Germany



- RS, Norway



- SSRS, Sweden



Lifeboats

- RNLI, UK

This document may be reproduced without the prior consent of the IMRF. The IMRF takes no responsibility for any outcomes as a result of this manual.

Disclaimer

The content of this manual is for general guidance only. It represents best practice as at the date of publication and should not be considered as legal advice. Those using this manual should seek professional advice as and when necessary. The IMRF does not accept responsibility for any errors in this document.

Foreword	1
Unit 1: Human factors	2
1.1 Human factors in SAR	3
1.2 Situational awareness	4
Unit 2: Personal protective equipment (PPE)	7
2.1 Personal Protective Equipment (PPE)	8
2.2 Maintenance and care of PPE	14
2.3 What to do should you end up in the water	15
Unit 3: Tide and weather	18
3.1 Tides	19
3.2 Weather	24
Unit 4: Basic navigation	29
4.1 Basic chartwork, navigation and buoyage	30
4.2 Latitude and longitude	39
4.3 Plotting a position	40
4.4 Plotting a course	44
4.5 Electronic navigation	45
Unit 5: Rules of the road – IRPCS	49
5.1 Key rules	50
5.2 Navigation lights	51
5.3 Sound Signals	53
Unit 6: Ropework	52
6.1 Ropework	53
6.2 Knots	55

Unit 7: General safety	58
7.1 Terms used	59
7.2 Types of boats	59
7.3 Stability	62
7.4 Types of engines and drives	63
7.5 Boat and engine spares	64
7.6 Boat safety equipment	65
7.7 Fire safety	66
7.8 Regular servicing and checks	68
Unit 8: Boathandling	71
8.1 Engine controls	72
8.2 Boathandling	73
8.3 Pivot points	74
8.4 Factors affecting boathandling	74
8.5 Boat handling in heavy weather	76
8.6 Approaching other vessels at sea	81
8.7 Mooring	84
8.8 Berthing	85
8.9 Beaching	87
8.10 Anchoring	88
Unit 9: Person in the water	92
9.1 Man overboard	93
9.2 Person recovery	95
Unit 10: Towing	99
10.1 Factors to consider when setting up a tow	100
10.2 Astern tow	100
10.3 Alongside tow	103

Unit 11: Distress and communication	106
11.1 Distress signals	107
11.2 Radio communications	110
Unit 12: Search and rescue (SAR) information and planning	115
12.1 Risk versus benefit	116
12.2 Search abbreviations	117
12.3 Tasking process	117
12.4 Types of searches	120
12.5 Setting up a search	121
12.6 Expanding square search	122
12.7 Sector search	123
12.8 Area searches	124
12.9 Rapid response method	126
12.10 Search techniques	126
Unit 13: Post-incident procedures	131
13.1 Post-incident procedures	132
13.2 Mental health and wellbeing	133
13.3 First aid	134





**Mr. Kitack Lim, Secretary-General,
International Maritime Organization (IMO)**

Safety of life at sea lies at the heart of IMO's work. Amongst other things, that means setting a global regulatory framework that works for everybody; and encouraging the integration of cutting edge technology, equipment and working practices into everyday shipping operations, to improve safety and reduce loss of life at sea. However, although shipping is a global industry, implementation of regulations and access to new equipment and the latest thinking is not universal.

This is why capacity building is one of the key strategies that IMO needs to address: helping to ensure that all countries, whatever level of maturity they have reached in their maritime activities, can participate effectively in the initiatives taken by IMO.

I am pleased to introduce this Basic Rescue Boat Operator Manual, produced by the members of the International Maritime Rescue Federation (IMRF). IMRF is focused on reducing loss of life in the world's waters and has contributed a great deal to the deliberations on maritime search and rescue (SAR) at IMO, as a non-governmental organization in consultative status since 1985. IMRF has also worked closely with IMO's Technical Cooperation Division to deliver training in maritime SAR planning, operational techniques and use of equipment, in regions where maritime SAR organizations are still being developed, or where they only have access to limited resources.

This manual, together with the accompanying Rescue Boat Operator Search Cards, will provide recommended best practice for any organization looking at introducing basic training in Rescue Boat SAR operations. I congratulate IMRF on this contribution to improving maritime SAR capability. I have no doubt that it will help to save more lives at sea.

Unit 1: Human factors



Learning outcomes

- 1.1 Understand the factors to consider during Maritime SAR operations
- 1.2 Understand the importance of constant situational awareness

1.1 Human factors in SAR

In SAR, few things are ever certain and many things can not be anticipated.

Effective SAR is characterised by planning, re-planning and adapting according to the present situation. This is because new information received at the beginning of a SAR mission can evolve and change radically throughout the event. It is therefore of great importance to understand that plans may need to be reviewed and revised as new information filters in during the mission.

The most effective way to deal with uncertainty is through harnessing and channeling optimum working relationships between people/groups/stakeholders. Creating effective conditions for people to work together requires that organisations strive to understand not only the technical aspects of SAR, but also the human aspects.

Maritime rescue is often time critical and stressful, there is always a risk of “tunnel vision” whereby the crew can have the potential to lose sight of the big picture and consequently may make mistakes. It is very easy to rush decisions or to cut corners, this can threaten a successful outcome. It is of utmost importance to use your training and take time to brief and plan coordinated actions carefully. No one benefits if the rescue boat has to abandon a rescue due to crew injury or damage to the boat.

A situation can also change very quickly as initial information can often be inadequate. This therefore highlights a need to be observant and open-minded as change will frequently occur in planning. There must be open communication between the crew, rescue boat and mission coordinators. Remember that you are the eyes, ears and hands on site.

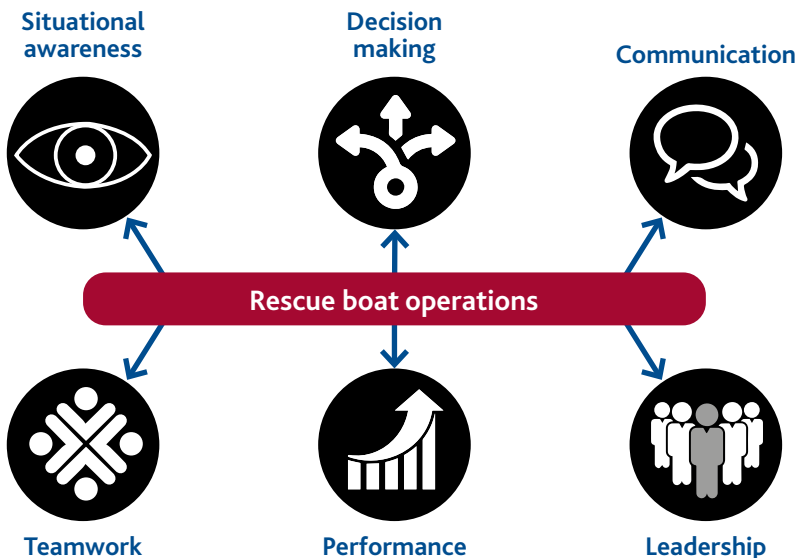

1.2 Situational awareness

What is situational awareness? Situational awareness is being aware of everything that is happening around you and how this may affect:



It is often described as a person's state of knowledge or mental model of the situation around themselves. Situational awareness is important for effective decision making and performance in any complex and dynamic environment. It is necessary for the rescue boat operator to put in place the means to continuously monitor the environment to detect changes and to ensure their understanding of the situation remains accurate. For example, an appropriate command structure and communication network.

A low level of situational awareness or incorrect mental picture has the potential to cause incorrect actions resulting in reduced effectiveness and accidents.

One study of aircraft accidents found that a very high percentage of all accidents occurred

due to an underlying problem with situational awareness.

Other studies have found that a similarly high percentage of human error problems stem from poor situational awareness, which often results from deficiencies in the system capabilities or displays provided to their operators.

Factors (included but not limited to)

- present and future weather
- present and future sea state
- present and future tide and tidal streams
- correct position and route planning
- other shipping
- progress of task in hand
- number of persons involved
- health, welfare and ability of SAR personnel
- condition of equipment.

It is important for all personnel involved in maritime SAR operations to carry out regular training.

Whilst developing Rescue Boat Operations, consideration should be given to the use of checklists/aide memoirs to help with a standardised approach to completing tasks.

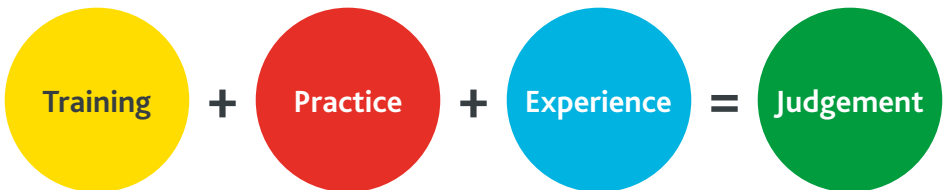

This manual is designed to give you the foundations and the skills to become a competent rescue boat operator.

Unit 1: Notes

A series of horizontal dotted lines for writing notes.

Unit 2: Personal protective equipment (PPE)



Learning outcomes

- 2.1 Know what personal protective equipment (PPE) is.
Know the different types of PPE to be used while afloat.
Understand the appropriate uses of PPE.
Be able to put on and adjust PPE correctly.
- 2.2 Know the maintenance and care that is needed for your PPE.
- 2.3 Know what to do if you end up in the water.

2.1 Personal Protective Equipment (PPE)

What is PPE?

Personal protective equipment, or PPE, is equipment or clothing provided to ensure that a person can carry out their own particular role in comparative safety when it is used or worn correctly.

PPE is only useful when correctly fitted and adjusted. Training is essential. It is the user's responsibility to check that PPE is maintained, cleaned, serviceable for use and is stored correctly.

Safety helmet

- Provides warmth.
- Provides impact protection.
- The face shield protects from the elements (and from blood during first aid).



Drysuits/wetsuits

- Designed for more extreme conditions.
- User is more likely to enter the water.

Maritime PPE

PPE for going to sea is primarily concerned with three main areas of personal safety. They are to keep a person:

- dry
- warm
- afloat.

Lifejacket

- Provides buoyancy.
- Ensures correct body orientation in the water.
- Offers some impact protection.



Foul-weather clothing

- Usually made up of a waterproof jacket and trousers.
- Not designed for entering the water.

Staying warm and dry

If you are operating at sea in cold conditions, it is important to stay warm and dry. You can use different types of clothing and PPE, adjusting them to the environment, as necessary.

Tips for staying warm

Wear layers; more layers will trap air between them and keep you warmer. Eating hot food and drinks can help combat the effects of the cold.

A drysuit could be worn. It has waterproof wrist and neck seals to keep you dry

Gloves will keep your hands warm but could make tasks like ropework more difficult and hazardous

A pair of goggles or a helmet visor can protect your face from rain and spray

Warm hat

Fleece

High fit trousers over thermal underwear

Adjustable trouser bottoms

Non-slip shoes over thermal socks

Eat and drink regularly

The infographic features a central illustration of a person wearing a grey drysuit, a blue beanie, and yellow overalls. To the left, there are illustrations of purple gloves, yellow and black goggles, a steaming cup of coffee, and a sandwich. Labels with leader lines point to various parts of the person's gear: 'Warm hat' points to the beanie, 'Fleece' points to the inner layer of the overalls, 'High fit trousers over thermal underwear' points to the overalls, 'Adjustable trouser bottoms' points to the bottom of the overalls, and 'Non-slip shoes over thermal socks' points to the boots. Text boxes provide additional information about each item.

Unit 2: Personal Protective Equipment (PPE)

Staying cool

If the conditions are particularly warm, then the user will want to wear clothing to try and keep them cool. The main function of this clothing is to keep the skin shaded from the sun.

Dehydration symptoms

Thirst, dry lips, dark urine colour are all signs of dehydration; rehydrate using water. Be aware, dehydration can lead to more severe medical issues, such as heat stroke or heat exhaustion.

Exposure to the sun can be dangerous. Try to avoid being in the sun between 11am and 3pm

11^{am} 3^{pm}

Wide brimmed hat to protect head, shoulders and neck

100% UV protection sunglasses

Lose, pale, long sleeve top

Reflection on water can increase the effect of the Sun

Apply sun block of SPF 30-40 regularly

Lose, pale trousers

Keep hydrated. Make sure you drink water regularly. DO NOT drink alcohol

WATER

The infographic features a central illustration of a person wearing a wide-brimmed hat, sunglasses, a long-sleeved shirt, and trousers. To the left, a large yellow sun is shown. To the right, a clock face highlights the time interval from 11 am to 3 pm in red. Below the person, a diagram shows yellow wavy lines representing sunlight reflecting off a blue surface (water) and hitting a red triangle, illustrating how reflection increases the sun's effect. To the right of the person, there is an image of a tube of 'SUN SPF 40' sunscreen and a plastic bottle of 'WATER'. The background is a blue sky and a yellow ground.

Personal flotation devices (PFD)

Buoyancy aid

A buoyancy aid has inherent buoyancy and will help the rescuer to float if they enter the water but it will not keep their head out of the water if they become unconscious. It needs to be a bright colour.



Lif jackets

There are many different types of lifejackets, including those with manual and automatic inflation. There are also foam lifejackets. A lifejacket is designed so that if you become unconscious it should keep your head above the water.

When they are inflated, lifejackets are sometimes larger than buoyancy aids and can be difficult to move in.

It is important that all PPE is the correct size and adjusted to an individual if it is to be effective.

Ensure that all straps and buckles are done up tightly and care should be taken to minimise the amount of loose ends.

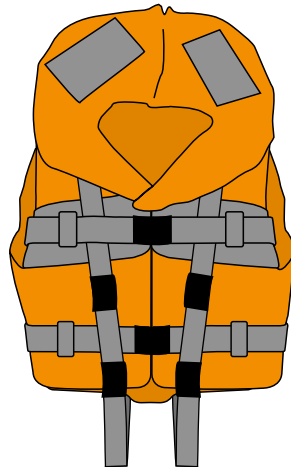

Unit 2: Personal protective equipment (PPE)

Foam lifejacket

Foam lifejackets are made of closed-cell foam. They do not inflate as the foam provides all the buoyancy required.

Advantages:

- relatively cheap
- minimal maintenance required
- easy to put on.

Disadvantages:

- bulky for storage
- restrictive to move in
- uncomfortable to wear for long periods of time.

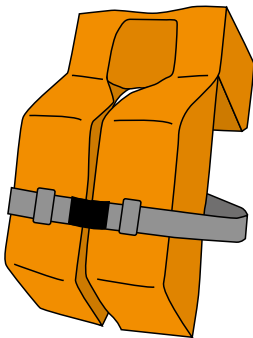

Automatic/manual-inflation lifejackets

Manual inflation lifejackets are activated by pulling the toggle, this mechanism releases gas from a cylinder to inflate the jacket. This can be a problem if the wearer is injured or unconscious and unable to manually inflate it.

Automatic lifejackets should inflate in the water. This is carried out with an automatic firing head. All automatic lifejackets can be manually inflated.

Advantages:

- more comfortable to wear as they are less bulky.

Disadvantages:

- once activated, the gas cylinder and components needs to be replaced, which can be costly
- need to be serviced regularly.

Lifejacket (stowed)

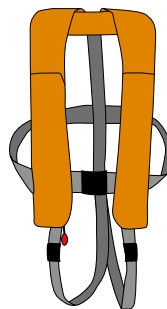

Lifejacket (inflated)

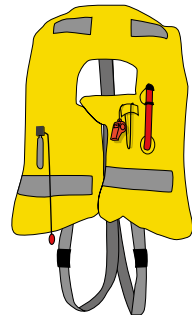

WARNING

There are different types of activation mechanisms on automatic and manual lifejackets. Ensure you are familiar with the one that you may have on your lifejacket.

Putting on personal protective equipment (PPE)

Buoyancy aid

Buoyancy aids come in a wide variety of designs. Some can be put on like a jacket while others are put on over the head and adjusted at the side.

The most important features of any buoyancy aid are that it fits comfortably, allows freedom of movement and helps you to float.

Make sure that any buckles are done up and straps are pulled tight so that the buoyancy aid fits properly. Lifejacket



Safety Harness

Search and rescue operations in adverse weather conditions (bad weather) can require crewmembers to move on deck to recover survivors or set up equipment. To prevent falling into the water, consider using a safety harness whilst operating on deck.



Lifejacket

When wearing a lifejacket it is vital that you fit it correctly, otherwise there is a danger that it may come off if you enter the water.

Ensure that any buckles are done up and any webbing straps are tightened.

Tuck away any excess webbing, so that it does not become a snag hazard.

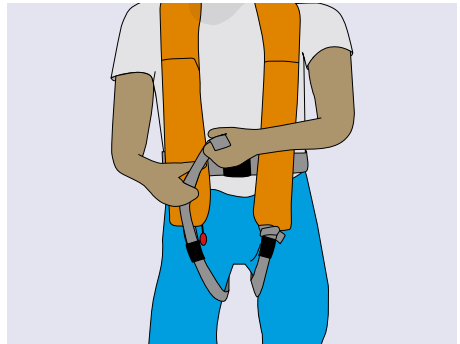

Sprayhood

A spray hood will keep wind-blown spray away from your airways, making it easier to breathe and reducing the risk of drowning. It will also act as a high-visibility detection aid and stop heat escaping from your head.



2.2 Maintenance and care of PPE

It is essential that PPE is regularly maintained. Wash down PPE with fresh water and allow the PPE to dry naturally before returning to stowage.

Inflatable lifejackets should always be stored in clean, dry conditions and must be thoroughly dried after use, before being returned to their stowage. Failure to do so may cause the lifejacket to inflate automatically, due to moisture build up. Perform the following routine checks on your lifejackets:



Check the webbing and the stitching every three months. Also check zips buckles and other fasteners.



Check the gas cylinder is tightly screwed in every month. Always carry rearming kits for each type of lifejacket that you have onboard. If a lifejacket is accidentally inflated, you will be able to get it ready for use again straight away.



Check the CO2 bottle for corrosion every three months. A rusty cylinder should be replaced.

Every 6 months, inflate the lifejacket manually with a hand pump (use a hand pump to avoid moisture build-up inside the lifejacket). Leave it inflated for 24 hours to ensure there are no leaks or damage. Repack the lifejacket according to the manufacturer's folding instructions. Out of season, the lifejacket should be partially inflated (which removes creases in the material) and stored on a non-metal coat hanger.

2.3 What to do should you end up in the water

Adopt the H.E.L.P. position when alone in the water

- Heat Escape Lessening Posture.
- Inflate the lifejacket.
- Cross the legs and bend them up towards the body.
- Cross the arms and hold onto the shoulders of the lifejacket.
- At night, activate the lifejacket emergency light if fitted. Try and place this at the highest point to ensure good all round visibility.



Adopt the "huddle" position when all together in the water

- Inflate the lifejacket.
- Everyone huddle together.
- Try to attach to each other using a yacht harness if available. Thread the harness around the waist bands or lifting strops of the other lifejackets, NOT around the lifejackets stole.
- Being linked together keeps the crew closer together which helps to retain body heat and maintain morale. It also increases the chance of being spotted.
- At night, activate lifejacket emergency lights.
- Constantly monitor each other.



Attract attention



A series of horizontal dotted lines for writing notes.



Learning outcomes

- 3.1 Understand what tides are and how tides will affect your ability to navigate safely.
Know where tidal information can be found.
Be able to calculate tidal stream.
- 3.2 Understand why checking the weather before going to sea is important.
Know where weather information can be found.

3.1 Tides

Definition

A tide can be defined as 'the movement of a body of water'.

This movement of water results in a regular and repeated rise and fall of the sea.

- The rise of the sea (tide coming in) is called a flood tide. At its maximum level, it reaches a period known as high water.
- The fall of the sea (tide going out) is called an ebb tide. At its minimum level, it reaches a period known as low water.

Tidal information

Tidal information can be obtained from a number of sources:

- tide tables
- newspapers
- internet
- almanacs
- tidal stream atlas.

Types of tide

Tides are caused by the gravitational effect of the sun and the moon on the earth.

The tides are described as spring tides and neap tides. In a lunar month there will be two spring tides and two neap tides separated by approximately 7 days.

The lunar cycle

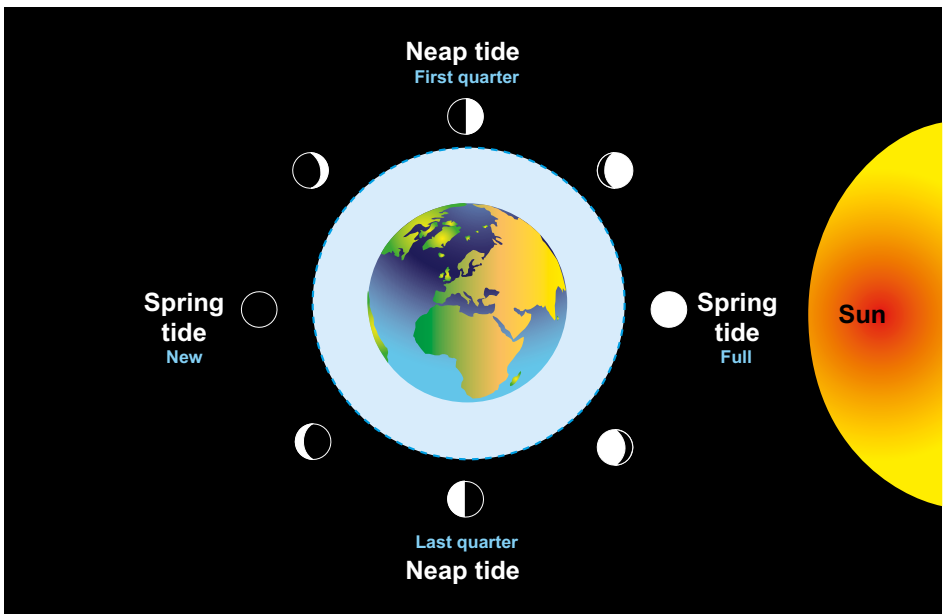

Unit 3: Tide and weather

Spring tides (Full and New Moon)

When the sun, moon and earth are in line, we get a spring tide. With spring tides we get higher high waters and lower low waters.

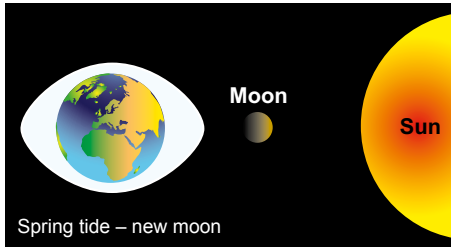

The gravitational pull of the sun and the moon are in line. This will give a linear pull on the water over the earth's surface resulting in:

HIGH high water
LOW low water

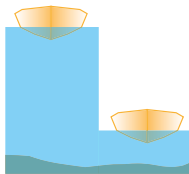

Neap tides (1st and 3rd Quarter Moon)

When the sun and moon are at right angles to the earth we get neap tides. With neap tides we get lower high waters and higher low waters.



The gravitational pull is now at right angles. This will evenly spread the water over the earth's surface resulting in:

MODERATE high water
MODERATE low water

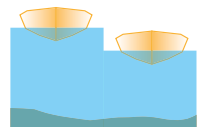

Tidal streams

Tidal streams are horizontal movements of water. They are affected by the shape of the land and the depth of the water. Generally, tidal streams:

- are strongest in deep, narrow channels and around headlands
- can make the sea rougher
- mean that watercraft operate on a moving carpet of water which means that the craft may not be travelling in the direction it is moving through the water
- mean that the speed over the ground (SOG) – the speed of actual travel – may be faster or slower than realised.

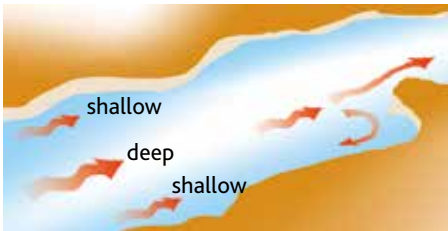

Tidal diamonds

Tidal information can be read from some nautical charts. This information is marked by a diamond-shaped symbol on the chart. Details of the tidal flow direction and rate are then shown in a table, which is printed on the chart for reference.



Tidal stream tables

Tidal Streams referred to HW

Hours	N070°15' E S 43°15' W		N078°15' E S 48°15' W		N071°15' E S 27°15' W		N075°21' E S 10°15' W		N070°45' E S 02°30' W	
	Dir	Rate (kts) Sp. Neap	Dir	Rate (kts) Sp. Neap	Dir	Rate (kts) Sp. Neap	Dir	Rate (kts) Sp. Neap	Dir	Rate (kts) Sp. Neap
Before HW	4 332	0.8 2.2	311	1.7 5.9	290	0.8 2.1	256	1.8 2.9	201	1.0 2.8
6	002	1.8 2.7	327	3.3 1.1	290	0.8 2.3	254	1.2 2.6	209	2.1 0.0
4	009	3.4 1.2	336	2.0 1.0	329	0.3 2.2	234	0.4 2.2	006	1.0 2.5
3	010	2.0 1.2	302	1.6 2.6	049	0.4 2.2	045	0.4 2.2	011	1.4 2.7
2	009	1.8 2.9	023	1.1 2.6	065	0.8 2.3	054	1.0 2.6	018	1.8 2.8
1	031	1.7 2.6	068	1.0 2.6	082	0.8 2.4	068	1.8 2.8	022	1.8 2.7
HW	123	0.0 2.3	112	1.4 2.7	097	0.9 2.4	067	2.3 1.1	028	1.3 2.8
After HW	1 188	1.3 2.8	114	1.8 2.9	107	0.7 2.3	078	1.8 2.9	029	2.4 2.2
2	181	2.5 1.2	127	1.8 2.9	124	0.4 2.1	082	0.8 2.8	202	0.4 2.2
3	194	2.0 1.3	106	1.8 2.9	201	0.3 2.2	203	0.4 2.2	199	1.2 2.6
4	210	2.1 1.0	169	2.0 1.0	234	0.4 2.3	223	1.4 2.7	198	1.7 2.5
6	229	1.1 2.6	232	1.6 2.8	263	0.9 2.4	247	2.3 1.1	197	1.6 2.8
8	286	0.8 2.2	286	1.4 2.7	278	0.8 2.8	287	1.9 2.8	202	1.2 2.8

Tidal stream tables provide specific data on tide direction and speed for the position indicated by the tidal diamonds. This is tabulated in 1-hour intervals either side of high water and shows rates for both spring and neap tides.

The information for each diamond is presented in the same way:

- the co-ordinates next to the diamond is the position in Latitude and Longitude at which the information was taken
- the first column of figures beneath each diamond is the direction of tidal streams in degrees true
- the second column of figures is the rate in knots of the flow of water on spring tides
- the third column of figures is the rate in knots of the flow of water on neap tides.

Unit 3: Tide and weather

Sawtooth

The Sawtooth is a visual and practical aid to understanding the direction and rate of the tide at any given time. Its purpose is to accurately predict the position of an object in the water after an elapsed period of time providing its last known position at a specific time is known. The following simple scenario will illustrate the Sawtooth method and the use of tidal diamond information.

Scenario

A report has been received saying that a person was spotted in the water at 11:00 at The Bellows. It is now 12:00.

Step 1, establish the required tidal information:

- determine, from the sources of information available to you, the time of high and low water
- whether the tides are springs or neaps.

19	06.00	0.7
	12.00	6.7
	M 18.00	0.7
	● 00.00	6.7

Looking at the example above you will see that:

- high water is at 12:00, 6.7m
- low water is at 18:00, 0.7m
- this gives a tidal range of 6 metres
- a spring tide is indicated by the date being in red and the presence of the new moon symbol.

Step 2, draw out an evenly spaced Sawtooth:

- insert the high water time, that is 12:00
- insert hourly intervals – the peaks above HW decrease by one hour while the peaks below HW increase by one hour
- insert half hourly intervals in the troughs
- insert the time the person was reported in the water (11:00) and the current time (12:00).

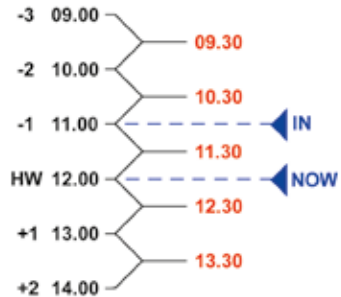

Step 3, plot the person's last known position (LKP) on the chart and compile the tidal diamond information:

In this scenario the nearest tidal diamond will be A.



The person was reported in the water at 11:00 – this is at the mid-point of the high water minus one hour (HW -1 hr) period.

By referring to the tidal information for diamond A, on a spring range the tide is:

- travelling at 253° at 0.2 knots.
- at 11:30 the tide alters course and flows on bearing 234° at 2.1 knots.

This means that the person will travel:

- half an hour on bearing 253° at 0.2 knots for a distance of 0.1 miles
- half an hour on bearing 234° at 2.1 knots for a distance of 1.05 miles.

Step 4, record the tidal diamond information on to the Sawtooth and plot predicted position of the person on the chart:

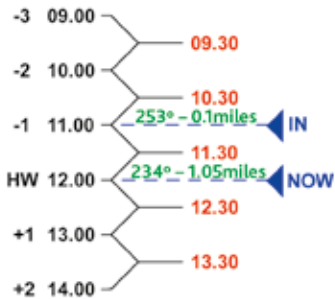

3.2 Weather

Effects of weather

Prior to going to sea, check the tide and weather forecast.

Rain and fog can cause reduced visibility. This increases the risk of collision and may restrict your ability to conduct a thorough search.

Prolonged exposure to the sun can cause dehydration, resulting in reduced concentration and an inability to perform tasks effectively.

An understanding of wind strength, direction and what effect it will have on your boat is essential. If the direction of the wind is against the tidal stream (wind against tide) the sea state will be worse.

The Beaufort scale on the following page will help to identify the characteristics of the sea in relation to the strength of the wind.

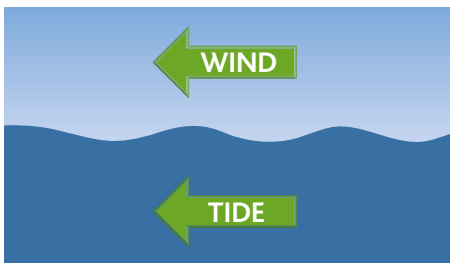
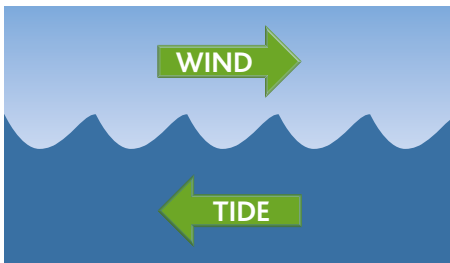

Weather information

Weather information can be obtained from a number of sources:

- television
- radio
- newspapers
- VHF radio
- internet
- local harbour or marina.



Remember: The wind speeds for each defined force on the Beaufort Scale must only be regarded as an AVERAGE speed. So gusts well up into the next force can be expected at times.

Beaufort Scale			Wind speed		
Force	Description	Sea characteristics	Knots	mph	km/h
0	 Calm	Like a mirror.	<1	<1	<1
1	 Light air	Ripples like scales are formed.	1–3	1–3	2–6
2	 Light breeze	Small wavelets, still short but more pronounced, not breaking.	4–6	4–7	7–11
3	 Gentle breeze	Large wavelets, crests begin to break; a few white horses.	7–10	8–12	12–19
4	 Moderate breeze	Small waves growing longer; fairly frequent white horses.	11–16	13–18	20–28
5	 Fresh breeze	Moderate waves, taking more pronounced form; many white horses, perhaps some spray.	17–21	19–24	29–38
6	 Strong breeze	Large waves forming; white foam crests more extensive; probably some spray.	22–27	25–31	39–49
7	 Near gale	Sea heaps up; white foam from breaking waves begins to blow in streaks.	28–33	32–38	50–61
8	 Gale	Moderately high waves of greater length; edge of crests break into spindrift; foam blown in well-marked streaks.	34–40	39–46	62–74
9	 Strong gale	High waves with tumbling crests; dense streaks of foam; spray may affect visibility.	41–47	47–54	75–88
10	 Storm	Very high waves with long overhanging crests; dense streams of foam make surface of sea white. Heavy tumbling sea; visibility affected.	48–55	55–63	89–102
11	 Violent storm	Exceptionally high waves; sea completely covered with long white patches of foam; edges of wave crests blown into froth. Visibility affected.	56–63	64–73	103–117
12	 Hurricane	Air filled with foam and spray; sea completely white with driving spray; visibility very seriously affected.	64+	74+	118+

Prevailing weather systems

Prevailing winds are winds that blow predominantly from an individual direction over a particular point on the Earth's surface. The dominant winds are the trends in direction of wind with the highest speed over a particular point on the Earth's surface. A region's prevailing and dominant winds are enacted by global patterns of movement in the Earth's atmosphere.

In general, easterly flow occurs at low and medium latitudes globally. In the mid-latitudes, westerly winds are the rule and their strength is largely determined by the polar cyclone. It is advisable to be aware of the local prevailing weather systems.

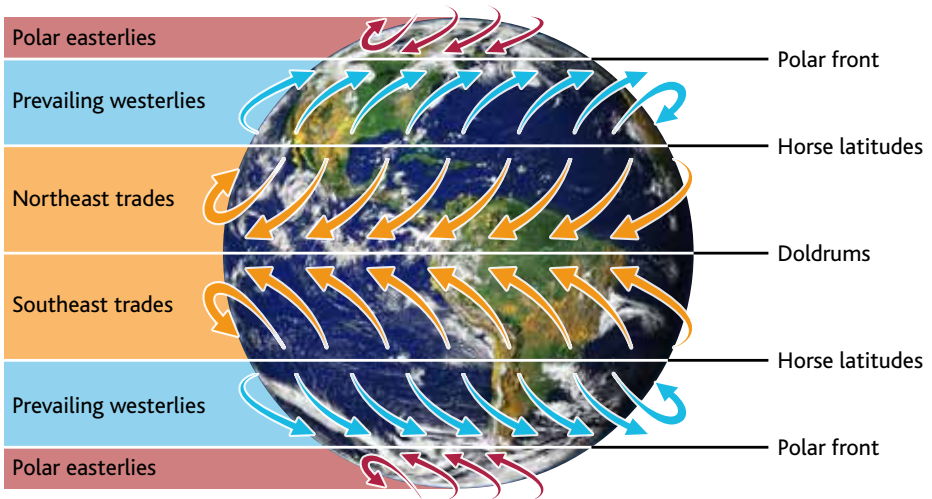

A series of horizontal dotted lines for writing notes.

A series of horizontal dotted lines spanning the width of the page, intended for writing notes.



Learning outcomes

- 4.1 Be able to do basic chartwork and navigation.
- 4.2 To understand latitude and longitude.
- 4.3 Be able to plot your position on a chart.
- 4.4 Be able to plot a course using a range and bearing.
- 4.5 To understand electronic navigation systems.

4.1 Basic chartwork, navigation and buoyage

There are many different makes of charts available. The main differences between these charts are colours, paper, type of information displayed, scale and layout.

A chart shows the nature and form of the coast, the depth of the water and general character and configuration of the sea bottom, location of dangers to navigation, the rise and fall of the tides, location of man-made aids to navigation and the characteristics of the earth's magnetism. Some of these are identified on the following page.

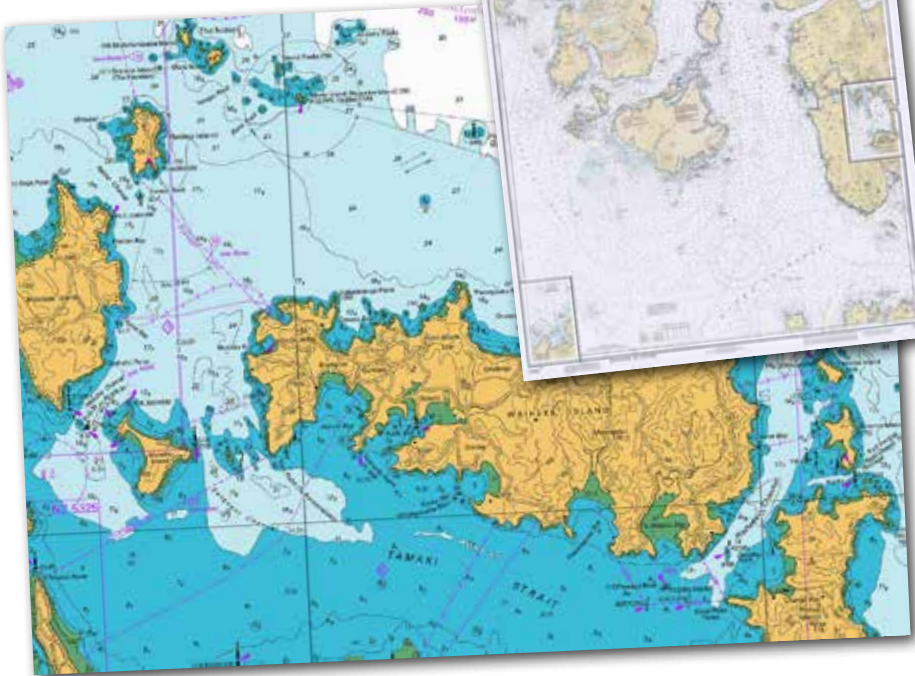

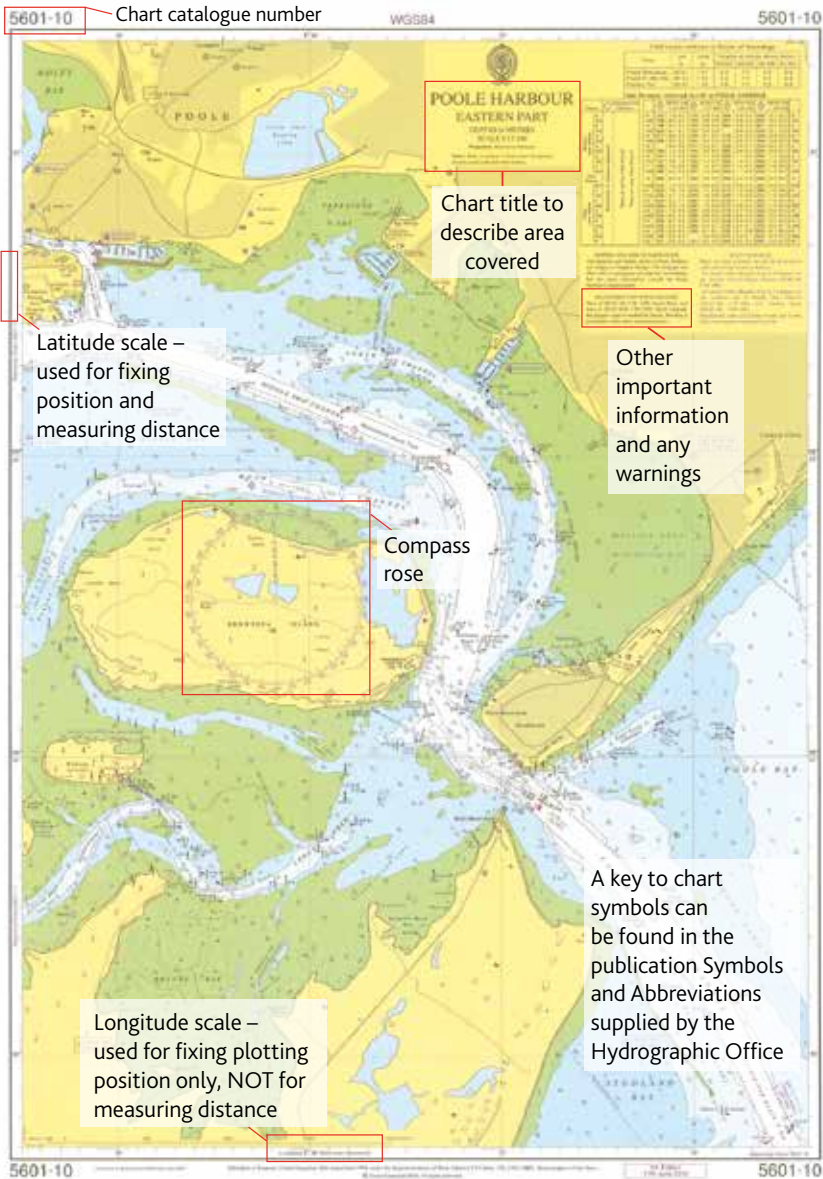

The chart above is reproduced with kind permission of The United Kingdom Hydrographic Office. (Crown Copyright 1998)

Unit 4: Basic navigation

Compass rose

The compass rose is used to measure angles and to create headings for use with the compass. It also contains information on the difference between true and magnetic north at its location.



Colours on charts

Various colours are used to distinguish between areas of the chart, such as land (yellow), drying heights (green), shallow water (blue) and deep water (white).



Latitude and longitude

The marked latitude and longitude scales appear at the edges of and at intervals across the chart and are used for finding/fixing position.



Tidal diamonds

Tidal diamonds may be situated at various positions on the chart. They tell the mariner that specific information regarding tidal direction and rates is available for that position. The tabulated information relating to these can be found elsewhere on the chart or in the chart pack.



Local information

Local information that may affect navigation is included on the chart or in the chart pack. This could include prohibited zones, military practice firing areas, dredging zones, overfall areas.

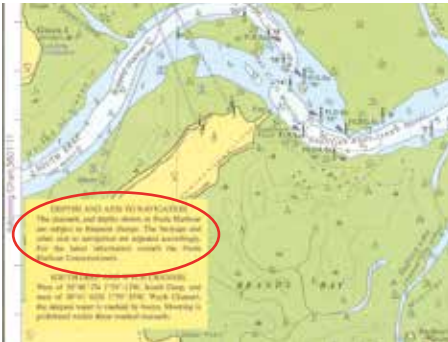

Chart symbols

On nautical charts, symbols and abbreviations are used to convey a lot of navigational information to the mariner. Each symbol has only one meaning, but it is vital that these 'coded messages' are correctly interpreted as many of them warn of specific dangers to navigation.

Unit 4: Basic navigation

IALA Maritime Buoyage System

The IALA Maritime Buoyage System defines two regions in the world: IALA A is used by countries in Africa, most of Asia, Australia, Europe and India. IALA B is used by countries in North, Central and South America, Japan, Korea and the Philippines.

The difference between the two systems is the colour and light characteristics used for lateral marks, as follows:

- IALA A port lateral marks and lights are coloured red. Starboard lateral marks and lights are coloured green.
- IALA B port lateral marks and lights are coloured green. Starboard lateral marks and lights are coloured red.

The similarities

Aside from the different lateral marks, both systems use identical cardinal, isolated danger, safe water and special marks.

For the purposes of this manual, we will be using the IALA Maritime Buoyage system for region A.



Key

- Region A (Port is red)
- Region B (Port is green)

IALA region A buoyage system

The following graphic shows a typical harbour using the IALA region A buoyage system.

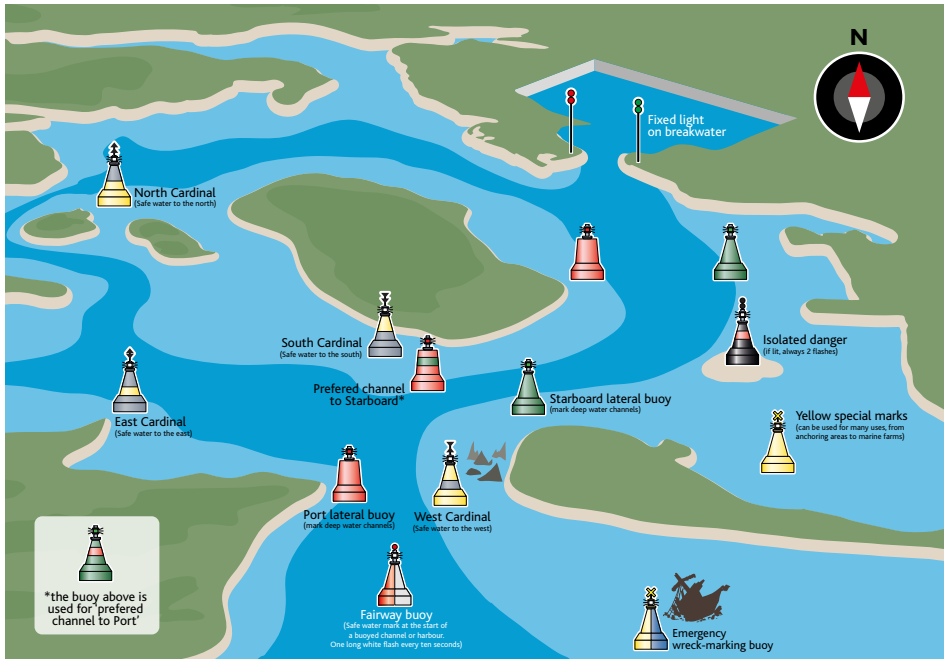

To aid identification, many buoys are lit. The light characteristics are often different but they will be shown on the chart. Common characteristics are flashing (Fl) when there is more dark than light, Isophase (Iso) when there is an equal amount of light and dark and Occulting (Oc), a rhythmic light when the period of light is clearly longer than the period of dark. A light showing at Fl(2) 10s means that the light will flash twice in a 10-second period.

Unit 4: Basic navigation

Cardinal mark

Cardinals refer to the four cardinal points of the compass and are directional buoys. That is, they indicate the way to go to find the best navigable water. The cardinals surround, or mark a hazard. Safe water is to the north, south, east or west of the respective cardinal mark.

Each buoy is coloured with its own combination of black and yellow bands and each of the top marks comprise a combination of two black arrows.

The shape of an individual buoy can also vary provided the defining features of colour and top mark are maintained. Lights, when fitted, are white and will flash in the dedicated sequences either quick or very quick.

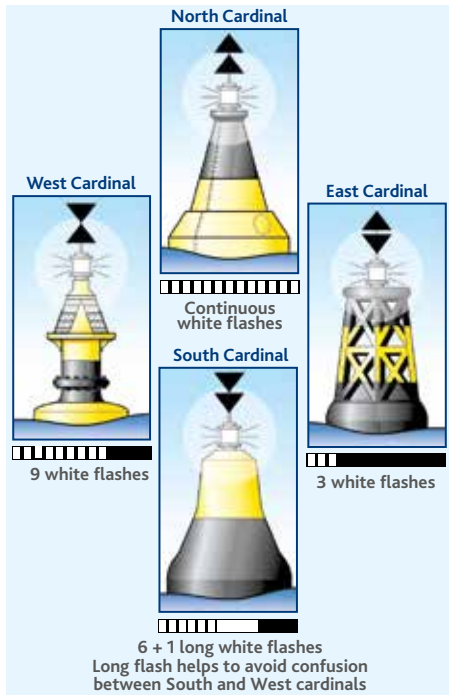

Lateral marks

Lateral marks are used to indicate well-defined channels. When used in conjunction with the direction of buoyage symbol on the chart they indicate the sides of the route to be followed.

The **PORT** mark is usually a **can** or **post**, coloured solid **red**. If a top mark is fitted it will be a single red can. When a light is fitted it will be **red**.

The **STARBOARD** mark is usually a **cone** or **post**, coloured solid **green**. If a top mark is fitted it will be a single green cone, pointed upward. When a light is fitted it will be **green**.

The sequence of light flashes can be anything with the exception of the 2+1 combination.



Preferred channel marks

These are modified lateral marks used to indicate the preferred route when a channel divides to form two alternative channels to the same direction.

To indicate that the preferred channel is to port, the starboard lateral mark is modified with a red band.

To indicate that the preferred channel is to starboard, the port lateral mark is modified with a green band.

Remember – the colour of the band indicates the way to turn to take the preferred channel.

A light when fitted is red or green as appropriate to the buoy and the sequence of flashes is 2+1.

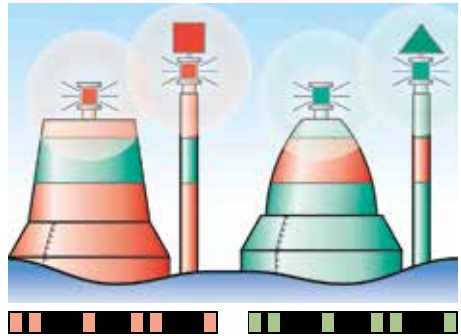

Special marks

Special marks locate areas of special interest. The nature of the marked feature is only apparent from reference to a chart. Special marks may be used for a variety of reasons, such as marking sewerage outfalls, swimming areas, historic wrecks.

The mark can be any shape but is always yellow. The top mark is a yellow cross.

A light, when fitted is yellow. The sequence of flashes may be anything not used by white lights.

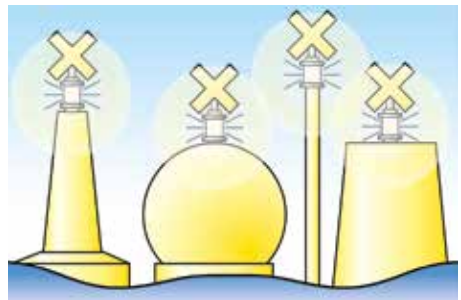

Unit 4: Basic navigation

Isolated danger marks

Isolated danger marks identify the location of isolated dangers of limited extent that have navigable water all around them.

Marks are black buoys or posts with one or more red bands around them. The top mark is two vertically aligned black balls.

A light, when fitted, is white and flashes in a group of two.

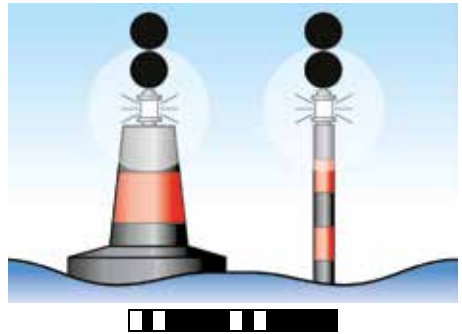

Safe water marks

Safe water marks indicate there is navigable water all round a mark. It may be used as a centreline, mid-channel or landfall buoy or to indicate best passage point under a bridge.

Marks are red and white striped buoys or red posts. The top mark is a single red ball.

A light, when fitted, is white. Sequence is Occulting (Oc), Isophase (Iso), Morse Code A (Mo(A)) or a single long flash in a period of 10 seconds (LFI.10s).

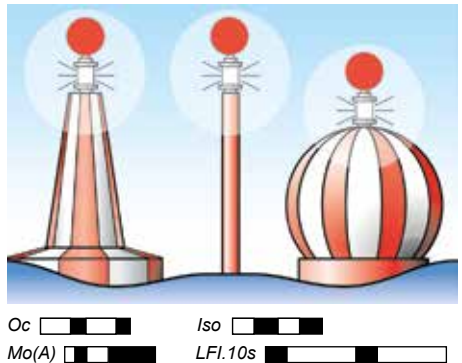

Emergency wreck marks

Emergency wreck marks temporarily locate the position of a wreck until a permanent form of marking has been carried out.

Marks are blue and yellow striped buoys or posts. The top mark is a yellow cross.

A light, when fitted, is an alternating blue and yellow flashing light where the blue and yellow 1-second flashes are alternated with an interval of 0.5 seconds.

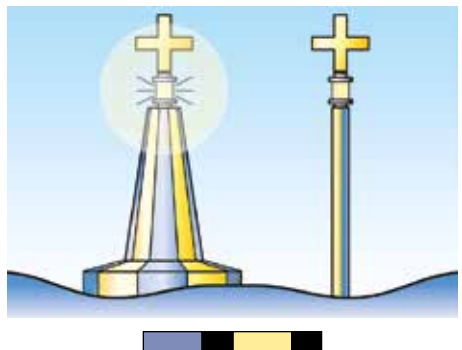

4.2 Latitude and longitude

Every location lies on a line of latitude and a line of longitude – a unique position.

Degrees of latitude are parallel, so the distance between each degree remains almost constant. Since degrees of longitude are farthest apart at the equator and converge at the poles, their distance varies greatly.

The lines of latitude start at the equator (0°) up to the North or South Poles (90°).

The lines of longitude start at the Greenwich Meridian (0°) around to the International Date Line (180°).

Parallels of latitude



On the latitude scale:

- 1° is equal to 60 nautical miles (NM).
- Each degree is split into 60 minutes ($60'$).
- $1'$ is 1 NM.
- 1 NM = 1852 metres.
- 1 NM = 10 cables.
- 1 cable = 185 metres.

Meridians or lines of longitude

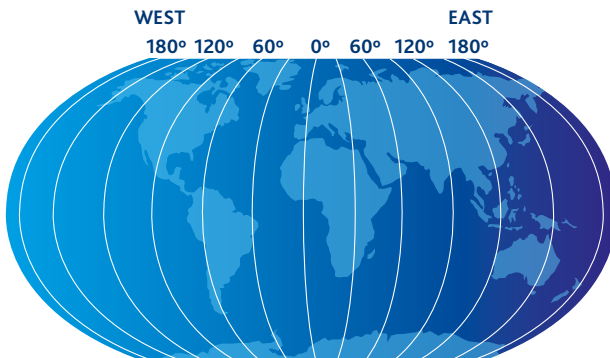

On the longitude scale:

- 1° is equal to 60 nautical miles at the Equator (0°), reducing the further North or South you move.

4.3 Plotting a position

A latitude and longitude can be obtained from a GPS, if available. To plot your position on a chart you can use a plotter, dividers or straight edge of a ruler. A plotter is easier to use on a small powerboat. Below are several tools you may need:



1 2B pencil or Chinagraph and a soft eraser

A well-sharpened 2B soft lead pencil needs to be soft so it does not leave a mark on the chart after it has been rubbed out. A clean gentle eraser and a pencil sharpener to keep your chart work accurate. An alternative to the pencil is a Chinagraph for use in wet conditions on laminated charts, check cards and publications.

2 Drawing compass

Used to draw distances and arcs onto chart.

3 The Portland speed, time and distance calculator

The Portland speed, time and distance calculator is a slide rule used to calculate speed, time or distance.

4 Dividers

Dividers are an accurate measuring device used for measuring distances on a chart.

5 Stopwatch

A stopwatch can be used for measuring time taken to travel a certain distance or the elapsed time travelled.

6 Rib plot

The rib plot is a smaller version of the plotter with no moving parts.

7 Bearing compass

Uses the earth's magnetism to determine horizontal direction. A compass is often fixed to the boat (ship's compass) or can be hand held (a bearing compass).

8 Plotter

The plotter is used to plot bearings and distances onto your chart.

9 Parallel rules

Normally carried on larger vessels where a large chart table is available. Used to transfer bearings and distances from one part of the chart to another.

10 Notebook

A notebook to maintain records.

To plot your position, first of all mark off the latitude. Make a horizontal line in the area you expect it to cross the line of longitude.

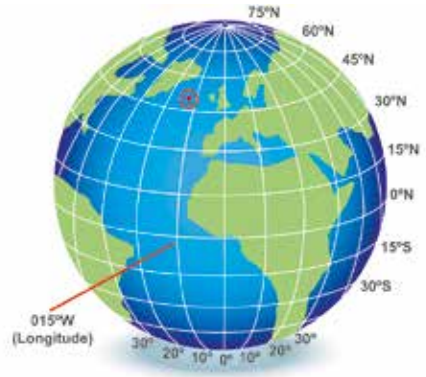
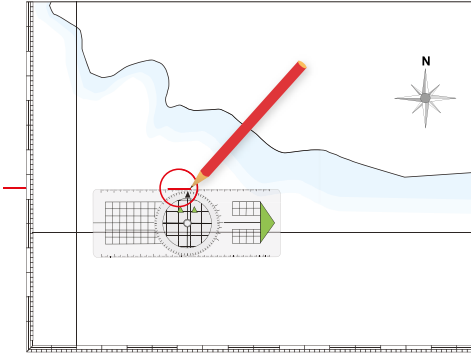

The position is $50^{\circ}43'35''$ $015^{\circ}16'6''$ W where the lines intersect

The position can then be transferred to the chart

Then mark off the line of longitude from the scale at the top or bottom of the chart.

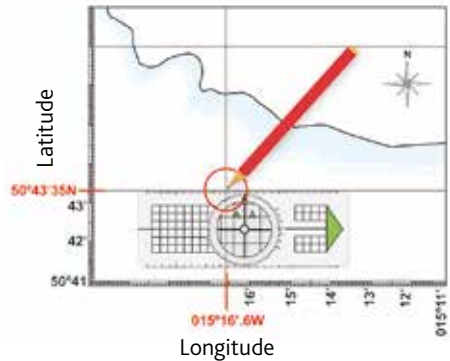
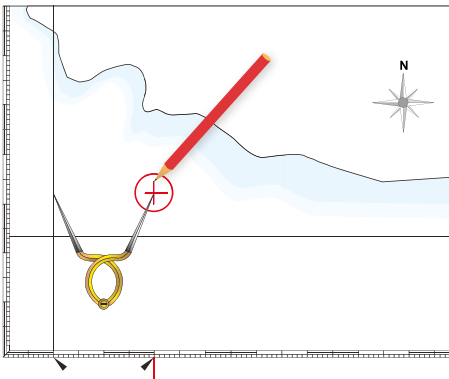

The actual position is where the lines cross.

Once you've fixed your position onto the chart, put a circle around it and note the time. Confirm your position using other references.

Unit 4: Basic navigation

Variation and deviation

On the chart, the lines of longitude are all drawn north–south. North on the chart is what we call True North.

If we draw a line on the chart between two points and measure it against the compass rose we can determine the True Bearing.

The navigator, however, has a problem: a magnetic compass does not point to True North! A large ferrous mass in the earth causes all magnetic compasses to be deflected to what is known as Magnetic North. This difference is known as Variation.

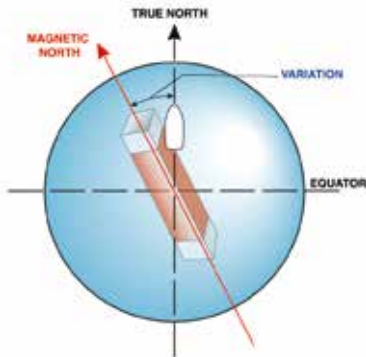

The magnetic compass can be further affected by items on the boat or the boat's magnetism itself. This effect is known as deviation.

When both the variation and deviation are taken into account, the resultant is known as the Compass Bearing.

NOTE

You should become familiar with the variation on the charts you are using.

A visual three-point fix

This technique is used to quickly confirm current position. To use this technique first identify three fixed charted features, preferably on shore. On the chart below the three features are a prominent house (1), a castle (2) and a directional light (3).



Use a hand compass to take your bearings

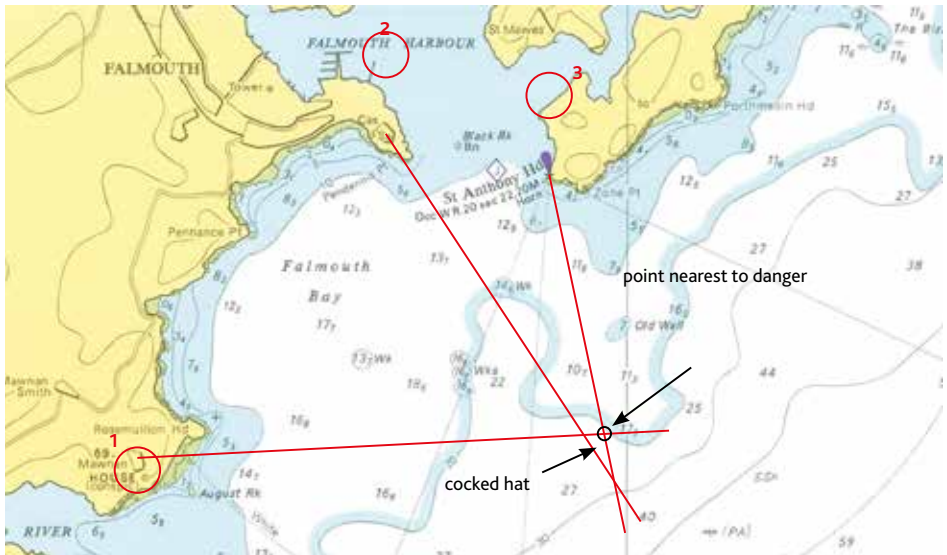

To plot a position:

- take and record a bearing to each feature
- note the time each bearing taken
- convert each bearing to true bearing
- plot the true bearings on the chart.

Due to the effects of wind and tide, it is unlikely that all three bearing lines will intersect at the same point. Instead, they will tend to form a small triangle, or cocked hat. The SAR unit's exact position is somewhere within this triangle and should be plotted at the point nearest to danger – in this case the point closest to land, indicated by a black circle.

4.4 Plotting a course

Draw a line from the start point to the destination. Check to see if there are any hazards along the route.

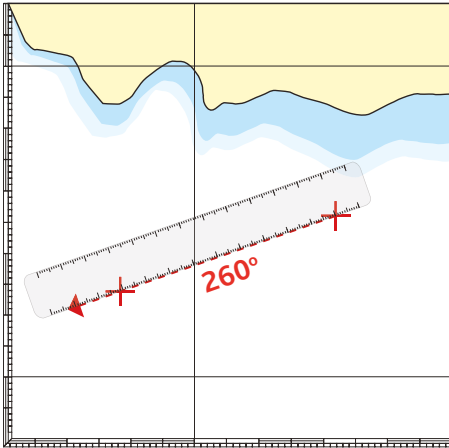

Range and bearing

Measuring range/distance on a chart

To measure the range or distance, place one point of the dividers at your start point and the other point at your finish point. Then take the dividers to the latitude scale on the side of the chart. Always use the latitude scale located in the same horizontal region that you are measuring.

Remember that 1' equals 1 nautical mile.

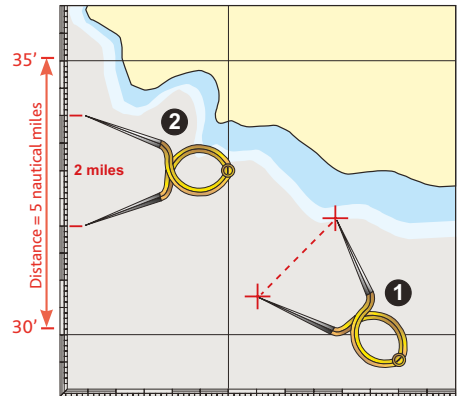

Take a bearing on a chart

Place the plotter along the line on the chart, with the arrow pointing in the direction of travel. Turn the wheel so that the arrow points north. Read off the bearing indicated.

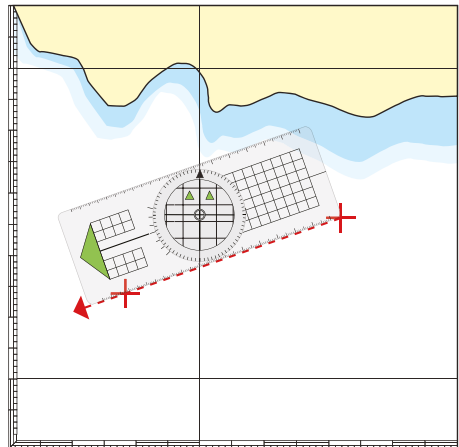

Read off the degrees on the compass rose – this gives you the bearing.

4.5 Electronic navigation

Rescue boats can be fitted with numerous electronic aids to navigation. They all work separately, but when combined they give us a host of tools to aid safe navigation.

Electronic navigation equipment

As with your computer at home the more familiar you are with it, the more you can achieve. All this equipment gives us large amounts of information and how we use that information can be the difference between a good navigator and a mediocre one.

GPS (Global Positioning System)

The most common way for the modern navigator to fix a position will be with GPS. The GPS uses satellites in space to triangulate, as long as it can receive the signals, it will give a very accurate position.

NOTE

GPS receivers do go wrong, so it is vital that navigators have more than one method to fix their position. GPS should be used in conjunction with a nautical chart.



Make sure that you are familiar with your particular kind of unit.

Radar



A well-tuned radar, used by a competent operator, is an extremely useful piece of equipment, not only for collision avoidance but also for navigation and search and rescue. It takes time and effort to learn this skill. On the flip side, a badly used radar can be a danger.

The word radar is an acronym, which comes from the phrase, RAdio Detection And Ranging. Radar is an electronic device that measures the bearing and distance of solid objects and presents this information on a screen.

It has three main functions on a rescue boat:

- to act as an anti-collision aid
- for fixing the boat's position
- to assist in casualty location.

Hazards posed by radar

There are some hazards from radar to be considered.

They are:

- radiation
- high voltage
- rotating aerial
- misleading information due to incorrect settings.

Chart plotter



A chart plotter is simply an electronic form of the paper charts. The plotter has taken this information and displays it on a monitor. The chart plotter is linked to a GPS receiver, either internally or remote. Once your location is detected by the GPS, your current position will be shown on the screen. When moving, your position will be constantly updated indicating your direction and speed.

Electronic charts are used more and more frequently onboard rescue boats, however care should be taken as they are not infallible and errors can happen. For this reason paper charts must still be utilised to confirm navigational accuracy.

Automatic Identification System (AIS)

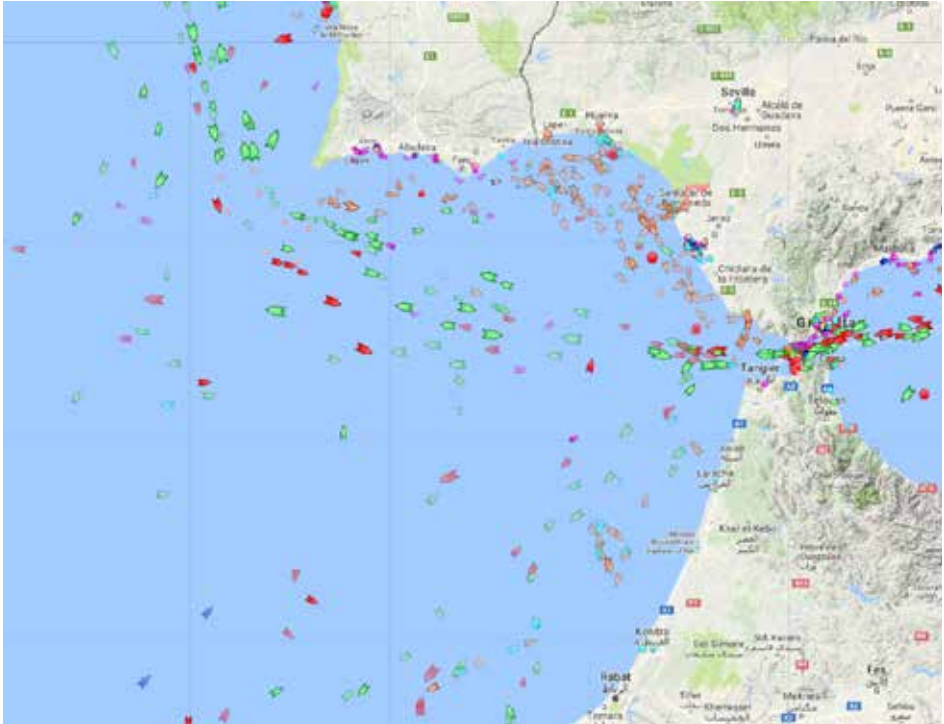

AIS is intended, primarily, to allow ships to view marine traffic in their area and to be seen by that traffic. This requires a dedicated VHF AIS transceiver that allows local traffic to be viewed on an AIS enabled chartplotter or computer monitor while transmitting information about the ship itself to other AIS receivers.

Port authorities or other shore-based facilities may be equipped with receivers only, so that they can view the local traffic without the need to transmit their own location. All AIS transceivers equipped traffic can be viewed this way very reliably but is limited to the VHF range, about 10–20 nautical miles.

A series of horizontal dotted lines for writing notes.



Learning outcomes

- 5.1 Know the key rules of the International Regulations for Preventing Collisions at Sea (IRPCS).
- 5.2 Know what navigation lights should be shown on your boat.
- 5.3 Know some key sound signals that may be used by vessels at sea

5.1 Key rules

International Regulations for Preventing Collisions at Sea (IRPCS)

There are many rules within IRPCS. Some of the key rules are listed below:

- **Rule No. 2 - Responsibility**

It is your responsibility to stay out of danger. Remember, nothing in the rules overrides common sense. If necessary, you may depart from the rules to avoid immediate danger.

- **Rule No. 5 - Lookout**

This rule states that a proper lookout must be maintained through a full 360° at all times, using all available means, such as looking, listening, radar, AIS (automatic identification system) and VHF.

- **Rule No. 6 - Safe speed**

This rule states that you should operate at a safe speed. This will change depending on factors such as visibility, density of traffic, manoeuvrability, background lighting, weather and depth.

- **Rule No. 7 - Risk of collision**

Constant bearing with decreasing range

A risk of collision exists when a boat is on a constant bearing with decreasing range.

Should you suspect that a risk of collision exists, take a series of bearings from your boat to the other boat. If these bearings do not change much as you are getting closer, there is a risk of collision. Take early action to avoid collision using the necessary rules of avoidance.



NOTE

It is important that a rescue boat operator has a good understanding of ALL IRPCS rules, not just the ones listed in this manual.

• Rule No. 8 - Actions to avoid collision

Head-on situation

When power-driven boats approach each other head-on, you should alter your course to starboard, passing down each other's port side.

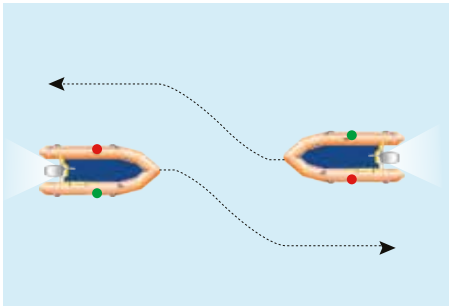

Crossing situation

When two power-driven vessels are crossing, if the vessel appears on your starboard side, you should steer to starboard to stay clear.

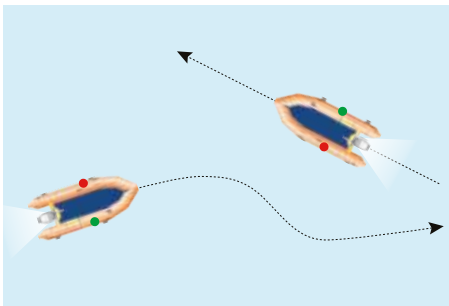

Top tips

If you see a red port light – give way.

or

Remember to give way to vessels on the right.

5.2 Navigation lights

- Navigation lights are the lights that a vessel should show between sunset and sunrise, and also in restricted visibility. The lights will vary according to the size of the vessel and will be different depending on whether it is a power-driven vessel or sailing vessel.

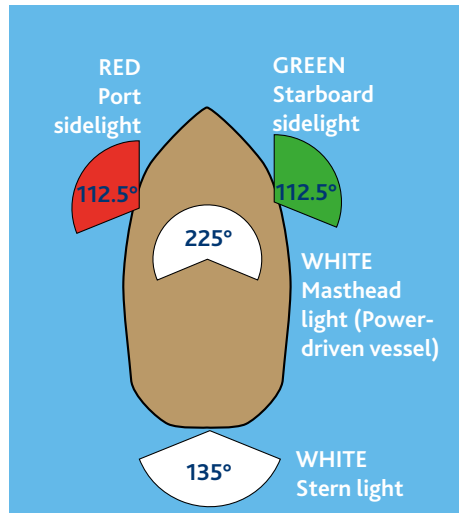

A standard power-driven vessel less than 50m in length would show the lights in the graphic above



A standard power-driven vessel – less than 7m in length, less than 7 knots speed, should display an all round white light. (As a bare minimum)

5.3 Sound signals

The following information covers Rules 32 – 35 of the IRPCS.

A range of sound signals are also used that come under three different categories:

- vessels in sight of each other
- vessels operating in a narrow channel
- vessels in restricted visibility.

The sound signals consist of:

- short blasts of between 1 and 2 seconds in duration
- long blasts of between 4 and 6 seconds in duration.

Vessels in sight of each other

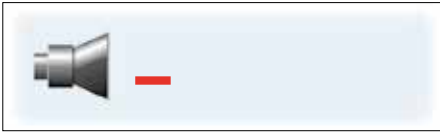

• 1 short blast

I am altering my course to STARBOARD.



• 2 short blasts

I am altering my course to PORT.



• 3 short blasts

My engines are running astern.

Note: This does not necessarily mean I am under way astern. For example, a large vessel slowing down.



• 5 (or more) short blasts

Your intentions are not understood.

Signals for vessels operating in narrow channels



- **2 long; 1 short blast**

I intend to overtake you on your STARBOARD side



- **2 long; 2 short blasts**

I intend to overtake you on your PORT side



- **1 long; 1 short; 1 long; 1 short blast**

This signals your agreement to be overtaken (this is the Morse Code C signal)

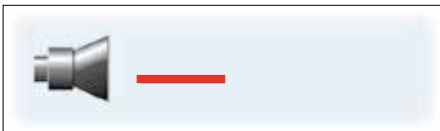

- **1 long blast**

I am approaching a bend in the river/channel but cannot see around it. Note: An approaching vessel should give one long blast in reply.

Vessels in restricted visibility



- **1 long blast every 2 minutes**

Signalled by a power vessel when under way and making way.



- **2 long blasts every 2 minutes**

Power-driven vessel under way but making no way.



- **1 long; 2 short blasts every 2 minutes**

Signalled by a vessel under sail, vessels fishing, towing, NUC, RAM and CBD.



- **1 long; 3 short blasts every 2 minutes**

Signalled by a vessel being towed (if manned). (This is the Morse Code B signal).

A series of horizontal dotted lines spanning the width of the page, intended for writing notes.



Learning outcomes

- 6.1 Know the terms used when describing a rope.
 - Understand the hazards involved when working with ropes.
 - Be able to prepare and throw a heaving line.
- 6.2 Understand the different types of knots and their uses.
 - Be able to tie each knot.

6.1 Ropework

Working ropes contain a great deal of energy with the potential to part and recoil, which could present a serious risk of injury to unaware crew. It is important that everyone operating on a rescue boat is aware of how to stay safe when working the deck to ensure that they don't become a casualty themselves.

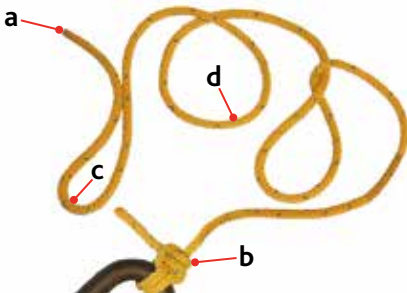

Terms used when describing rope:

- a. Running end/working end
- b. Standing part
- c. Bight
- d. Loop

Safety points for working with ropes:

- NEVER stand on a rope, in a bight, within a loop or in the line of recoil.
- When slipping or undoing a rope under load, extreme caution must be taken to avoid the rope from running away out of control.
- Make sure you are vigilant at all times when working with bits, blocks, cleats, capstans or bollards to prevent hands from becoming trapped when a rope slips.

- The wearing of rings is strongly discouraged. Serious injury, including amputation may result if a ring snags.
- Wearing gloves when handling rope and wire carries certain risks. Therefore, the wearing of gloves is left to the discretion of the crew.



NEVER stand within a bight



NEVER in front of a leading block



NEVER stand within a coil stand

Throwing a rope

There are many situations in which a crew member may be required to throw a rope, for example, when tying up alongside a pontoon or when setting up a tow on a casualty boat. It can be very difficult to coil and throw a thick rope, so a heaving line could be used.

Heaving line

A heaving line is a light, flexible line with a weighted end (such as a monkey's fist), which can be thrown between boats or the shore easily.



A heaving line can be used to pass a tow rope to a casualty boat or a berthing rope to a pontoon. It can also be used to act as a messenger line between two boats.

Preparing for throwing

Prepare the heaving line for throwing by firstly checking that it is free from knots and kinks.

The heaving line also works better when wet.

Coil the heaving line neatly then split the coil into two, with the weighted end in your throwing hand.

Never secure the end to your body.

It can be dangerous if the heaving line is thrown while the boat's propellers are turning.

Before throwing the heaving line the following should be taken into consideration:

- the weather conditions, especially the wind
- the throwing position, which should be clear of other people and any snag hazards.

Throwing the heaving line

The heaving line is best thrown with the throwing arm straight. Allow the heaving line to run freely out of the non-throwing arm.



6.2 Knots

Round turn and two half hitches

Easy to tie and can be undone while under load.

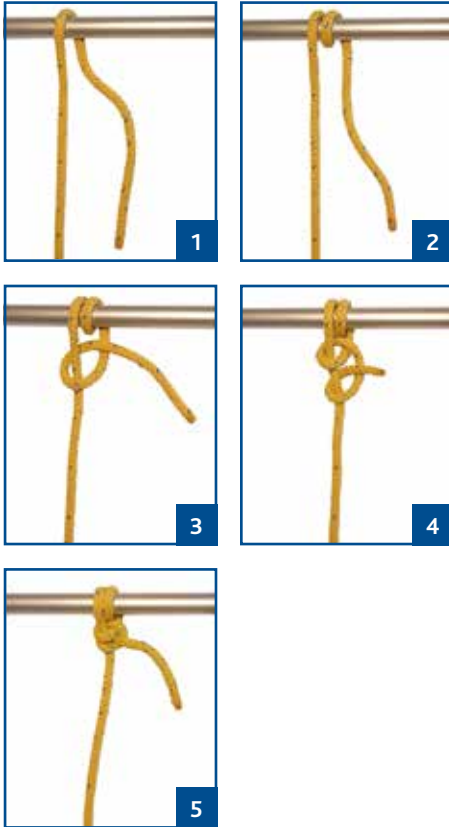

Appropriate uses for this knot:

- Secure a rope under load to a spar, ring or shackle.

Clove hitch

Good for fenders and light loads, can work loose.

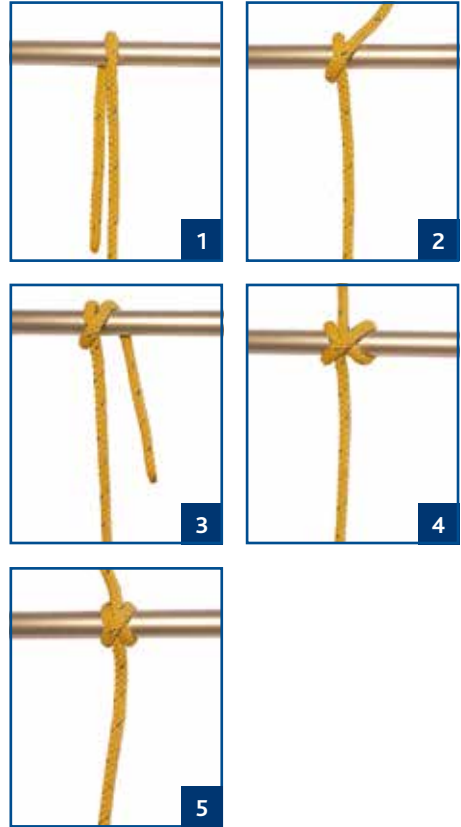

Appropriate uses for this knot:

- Secure a rope to a spar, rail, ring, post or similar fitting.

Unit 6: Ropework

Double sheet bend

Good for joining two lines, especially if they are different thicknesses. It can only be undone without a load on.



Appropriate uses for this knot:

- Join two ropes together of unequal thickness.

Bowline

The most used knot in boating. Will take a great load and can still be released. Can only be undone when there is no load.

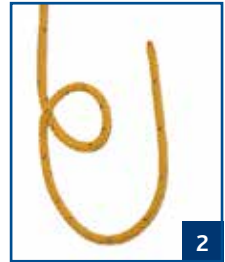

Appropriate uses for this knot:

- A temporary eye in rope of all sizes.
- Use as a lifeline.

Reef knot

Good for joining two lines of equal thickness.

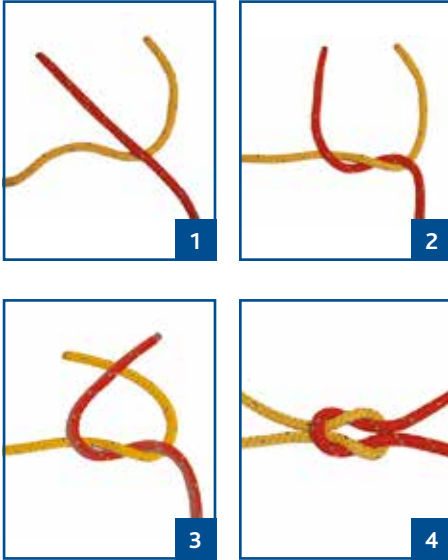

Appropriate uses for this knot:

- Join two ropes together of approximately equal thickness.
- Tie the ends of a rope around an object, for example, a sack or sail.



NOTE

When working with ropes, it is good practise to carry a knife.

Cleating off

- Take a complete turn around the cleat.
- Follow this with two figures of eight.
- Finish with a complete turn.

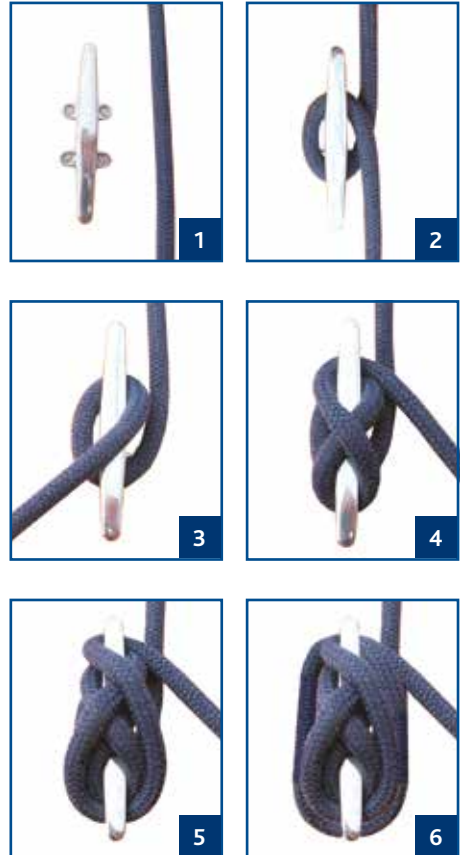

Unit 7: General safety



Learning outcomes

- 7.1 Know the terms used to describe the different areas of a boat.
- 7.2 Know the different types of boats that could be used for rescue operations.
- 7.3 Understand how overloading a boat affects its stability.
- 7.4 Know the different types of engines and drives.
- 7.5 Know the different spares that should be carried for the equipment and type of boat you have.
- 7.6 Know the recommended safety kit to be carried on the rescue boat. Know where the safety items are located on the boat.
- 7.7 Understand the basics of fire safety.
- 7.8 Understand the importance of maintenance and care of equipment.

7.1 Terms used

Different areas of a boat are given particular names to avoid confusion.

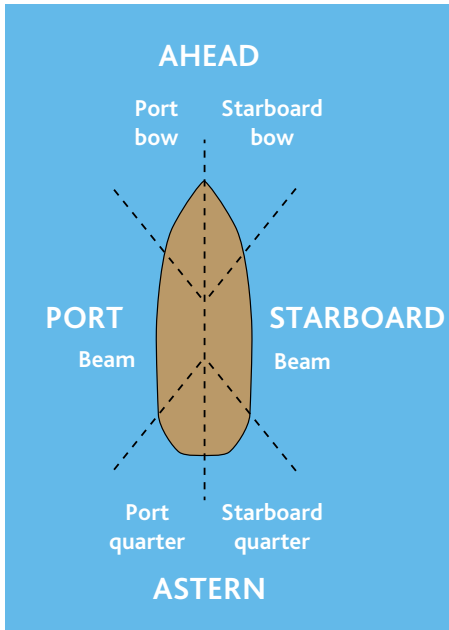

7.2 Types of boats

Inflatable boats

Inflatable boats usually have a semi-rigid floor and rigid transom. The inflatable areas are separated in case they are damaged. This isolates the damage to one area and not to the whole of the boat. Inflatable boats sometimes have an inflatable keel fitted that helps manoeuvre the boat more easily.

Advantages

- Good handling ability.
- Can be waded easily in shallow water.
- Can be repaired easily.

Disadvantages

- Can be uncomfortable for operators.
- Limited endurance.
- Limited space for equipment and personnel.

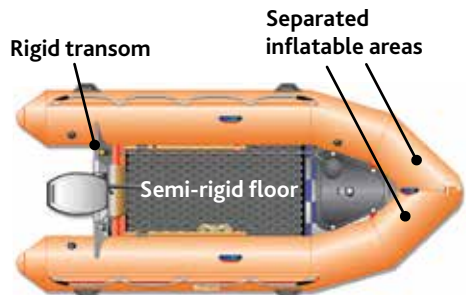

Rigid inflatable boats (RIBs)

The rigid inflatable boat (RIB) is a combination of the inflatable and rigid boats.

Advantages

- RIBs tend to be larger than inflatable boats, and therefore can carry more people.
- Generally a better sea capability than inflatables.

Disadvantages

- RIBs have higher sides than inflatable boats, which may make it harder to get casualties into the boats.
- They may not be as stable as inflatable boats, especially if they take on water.
- Limited space for equipment

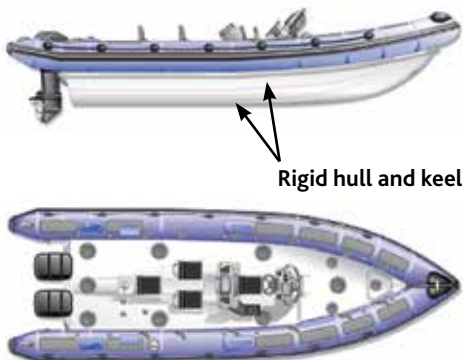

Open top rigid boats

Rigid boats are the most common boat type. They have the greatest variety of hull shapes, and many types of materials can be used for their construction.

Advantages

- There are many varieties available, which means that there is probably a model available that is suitable for most rescue needs.
- Most can be launched from a slipway and operated in shallow water.

Disadvantages

- Rigid boats have higher sides than inflatable boats, which may make it harder to get casualties into the boats.
- They may not be as stable as inflatable boats, especially if they take on water.



Closed cockpit boats

Closed cockpit boats have a variety of hull shapes. Many types of materials can be used for their construction.

Advantages

- Can operate in most weather conditions.
- Can have a longer range capability.
- Give good protection in adverse weather.

Disadvantages

- Can be expensive to run and maintain.
- Need a larger team to operate.
- Usually can not operate in very shallow water.



Skiff

A skiff can be made out of wood or fibreglass and is commonly used as a fishing boat.

Advantages

- Readily available locally.
- Easily repaired.
- Can be beached.

Disadvantages

- Can become very unstable if overloaded.
- Limited operational capability.



7.3 Stability

Rescuers should be aware of the limits of the boat they are operating. They are responsible for making sure the boat is correctly balanced, which includes checking the maximum number of people and the maximum combined weight of people and equipment that should be carried onboard.

Do not overload the boat.



Free surface water effect

Free surface water effect is when water collects in the boat and is allowed to move freely.

This could affect the stability of the boat if the weight shifts due to crew movement, a sharp turn or sea state. The rescuer should ensure that the minimum amount of water is allowed to collect in the boat.

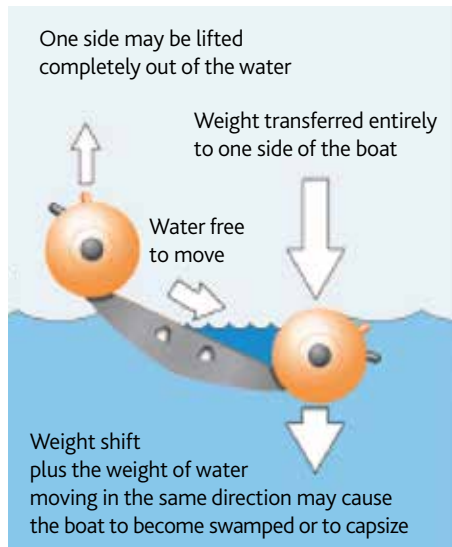
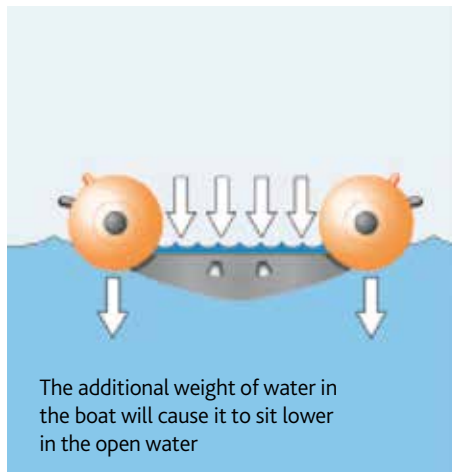

7.4 Types of engines and drives

An inboard engine can be run on petrol or diesel. Diesel is more common and has better fuel efficiency.

Inboard engines are usually easy to maintain because you can access all of their parts. If regular maintenance is carried out, diesel engines can be very reliable.

The inboard engine can be connected to many different drive systems, for example, shaft drive, outdrive or jet drive.



Shaft drive

Shaft drive systems provide a fixed direction of thrust and use rudders to steer the boat.



Outdrive

An outdrive directs its engine 'leg' to provide directional thrust to steer the boat.

Outboard engines run on petrol and are self-contained units that can be removed from the boat.



Outboard engine

These engines can be trimmed in shallow water and steered by either a direct tiller or remote steering wheel.

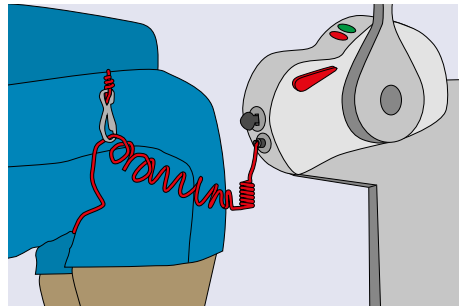

Kill cord

A kill cord will stop the engine if you move away from the helm or if you fall out of the boat. This then stops the boat running away and injuring you or others.

Always check that the kill cord works. Attach it to yourself, preferably around the leg, whenever the engine is running.

7.5 Boat and engine spares

Each boat should carry spares for the equipment and type of boat you have. Some examples are:



Belts



Fuel filters

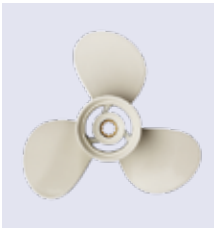

Propeller



Bulbs



Spark plugs



Inflation pump for inflatable boat



Puncture repair kit for inflatable boat



Bungs – for repairing holes in own boat



Basic toolkit (spanners, screwdriver)



Oil



Impeller



Fuel can

Do not dispose of oil, fuel, used equipment or items of rubbish overboard.

When carrying out maintenance such as oil changes or applying antifoul coatings on the hulls, consider the protection of the environment and follow appropriate regulations.

7.6 Boat safety equipment

You should consider having the following safety equipment items on your boat:

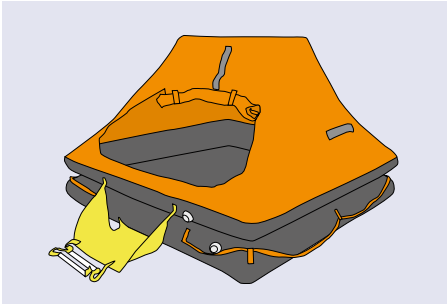

Liferaft

A liferaft is an emergency craft that can be used if the main boat is damaged. It can also be used to help survivors from another boat if space is limited onboard.

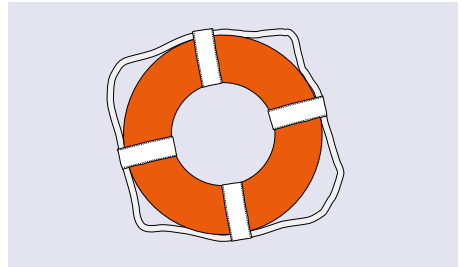

Lifering

A lifering should be fitted with reflective materials and marked with the boat's name.



First aid equipment

A comprehensive first aid kit should be able to deal with most minor injuries onboard. It should also have bandages to deal with severe bleeding.



Immersion suits

An immersion suit is designed to reduce the effect of cold water if the wearer has to abandon ship. Many immersion suits also aid flotation.



Fire extinguisher

A fire extinguisher should be carried for use in case of a fire.

7.7 Fire safety

Fire onboard is every mariner's worst nightmare. As a rescue boat operator, you should have an understanding of basic fire chemistry and have the means to extinguish a fire aboard your boat.

The fire triangle

Fire is a chemical reaction between oxygen in the atmosphere and a fuel source. A fire requires three elements to start:

- fuel – this is any combustible material, such as wood, oil, paper, etc.
- oxygen – abundant in the air around us
- heat – naked flames, hot surfaces, electrical sparks.

These links are graphically represented by the Fire Triangle below.

Fire will continue to burn for as long as the three elements, oxygen, fuel and heat, are present. Remove any one of the elements and the fire will go out.

However, before attempting to remove any one element, the nature of the fire must be understood. For instance, pouring water on a fire which involves burning metal, such as lithium, will actually cause more heat to be given off, sustaining the fire, and may even lead to explosion.

Consequently, different types of fires are assigned different classes and there are different types of fire extinguisher for each class of fire.

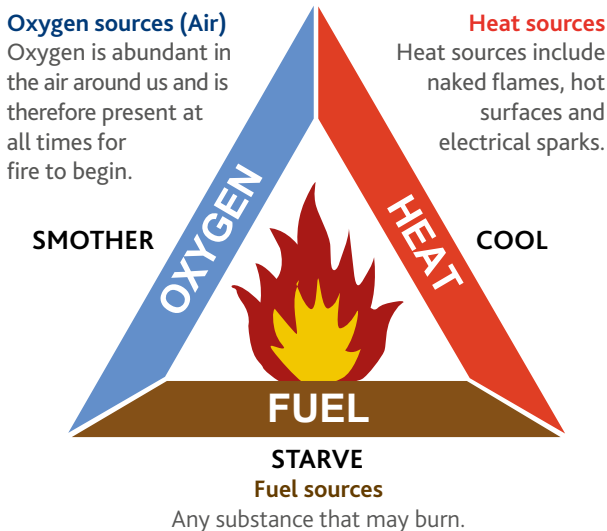

Types of fire

The different types of fire are classified as follows:



CLASS A

carbonaceous
for example:

- wood, paper, textiles, charcoal



CLASS B

liquids, liquefiable solids
for example:

- oils, petrol, diesel



CLASS C

gases, liquefiable gases
for example:

- butane, methane, propane



CLASS D

liquids, liquefiable solids
for example:
oils, petrol, diesel



ELECTRICAL (LIVE)

for example:

- navigation equipment, radios, radar



CLASS F

cooking oils and fats
for example:

- olive oil, maize oil, lard, butter

Each fire type presents different hazards, therefore they cannot all be treated in the same way.

Portable firefighting appliances

You should be aware of the location and type of all the fire extinguishers and fire blankets around your boat. You must also be aware that for each classification of fire there is an extinguisher that is suitable for dealing with the type of material involved in that fire.

Every extinguisher incorporates a universal system of letters, colours and symbols to help ensure the correct extinguisher is chosen for the relevant class of fire.

Different types of extinguisher remove different elements from the Fire Triangle in order to put the fire out. Some types remove more than one element.

Water – for class A fires

- Class A fires only.
- Aim at base of fire.
- **Do not use** on fires involving liquids or live electrical equipment.



Type: Water
Removes: Heat
Label: Red



Foam – for class A and B fires

- Class A and B fires.
- Use for a period, let the blanket form, then reapply if fire is not extinguished.



Type: Spray foam
Removes: Heat/Oxygen
Label: Cream



Wet Chemical – for class A and F fires

- Class A and F fires.
- Wet chemical knocks the flames out, cools burning oil and chemically reacts to form a soap-like solution, sealing the oil preventing reignition.



Type: Wet chemical
Removes: Heat/Oxygen
Label: Yellow



Dry Powder – for A, B, C, Live Electrical

- Class A, B, C and Live Electrical fires.
- Decreased visibility when used.
- Fuel may reignite.



Type: Powder
Removes: Oxygen – forms a vapour-tight seal blocking out the oxygen and chemically interrupts the fire chain.
Label: Light Blue



CO₂ - for class B and Live Electrical

- Class B and Live Electrical fires.
- Cold discharge/horn cylinder.
- Safe to use on electrical equipment that is live.



Type: Carbon dioxide
Removes: Oxygen
Label: Black



7.8 Regular servicing and checks

The organisation should endeavour to establish a system of maintenance routines for all equipment including:

- identification of safety critical elements and potential operational failures, with specific control measures
- inspection and testing protocols
- maintenance programmes and maintenance records – the crews should be equipped to suit their tasks, roles and responsibilities
- suitable training in order to ensure correct use of the equipment.

Make sure that you are familiar with your own engine and layout.



.....
.....
.....
.....
.....
.....
.....
.....
.....
.....
.....
.....
.....
.....
.....
.....
.....
.....
.....
.....
.....
.....
.....
.....
.....
.....
.....
.....
.....
.....
.....
.....
.....
.....
.....
.....
.....
.....
.....
.....
.....
.....
.....
.....
.....
.....
.....
.....
.....
.....
.....
.....
.....
.....
.....
.....
.....

A series of horizontal dotted lines for writing notes.



Learning outcomes

- 8.1 Know the different types of engine controls on boats.
- 8.2 Be able to drive the boat safely in different situations.
- 8.3 Be able to use pivot points in order to manoeuvre the boat.
- 8.4 Understand the factors that can affect boathandling.
- 8.5 Be able to handle a boat in heavy weather.
- 8.6 Be able to approach other boats at sea
- 8.7 Be able to approach and secure a boat to a mooring buoy.
- 8.8 Know what to consider when berthing.
Be able to berth your boat (if applicable to your local situation).
- 8.9 Understand how to beach a boat safely.
Be able to beach your boat alongside a stationary object.
- 8.10 Know the reasons to anchor.
Understand the factors that affect anchoring.
Be able to anchor safely.

Unit 8: Boathandling

Every vessel will behave differently in the water depending on lots of different factors, such as drive system, loading and hull shape. Different engines have different controls. It is important that the operator becomes familiar with the controls of the vessel they will be operating.

8.1 Engine controls



Twist throttle

Commonly found on outboard engines and operated like a motorbike throttle. Gears are usually found on the side of the engine but could be part of the twist grip.



Single throttle

Single throttle controls can be found on both inboard and outboard powered vessels. A single engine is controlled by one lever. Pushing the levers forward for ahead, pulling backwards for astern and positioning centrally for neutral.



Dual throttles

Dual throttle controls can also be found on both inboard and outboard powered vessels. Two engines are controlled by two individual levers. Each lever works the same as a single throttle control. Having two engines that can be controlled independently give the boat extra manoeuvrability.

8.2 Boathandling

Steering the boat

Boats are normally steered using either a tiller or a wheel. Some more modern boats are now using joystick control.

Outboard/Drive

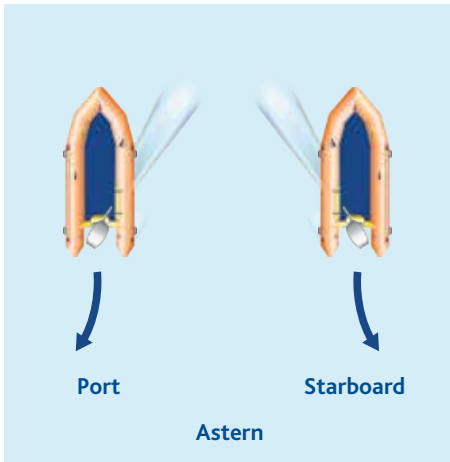
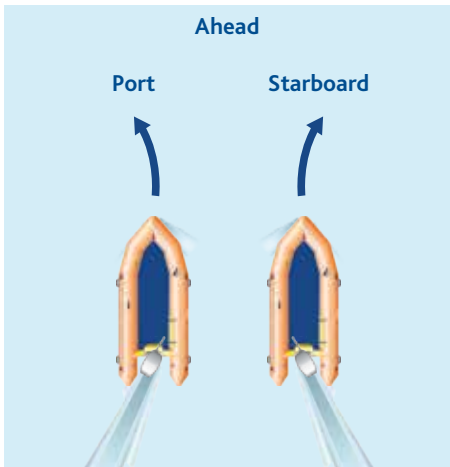

Fixed shaft (propeller and rudder)

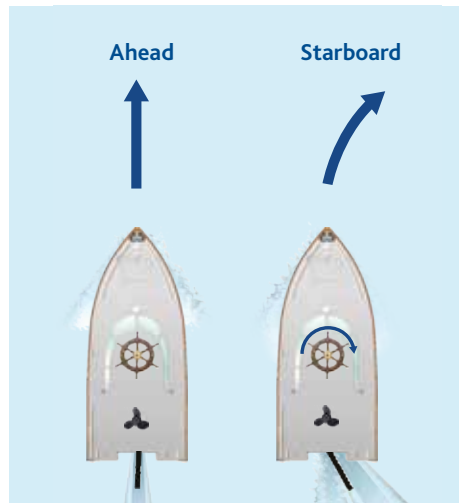
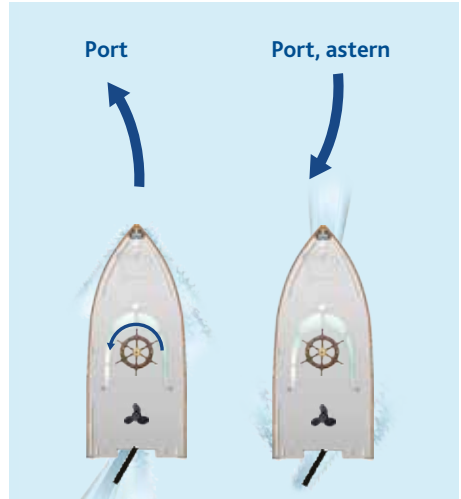

Note, due to the effect of the propeller, a fixed shaft drive will noticeably drag to one side in astern.

8.3 Pivot points

In forward gear, a boat pivots around a point forward of its centre. When going astern, the pivot point moves towards the back (aft), making the turn tighter.

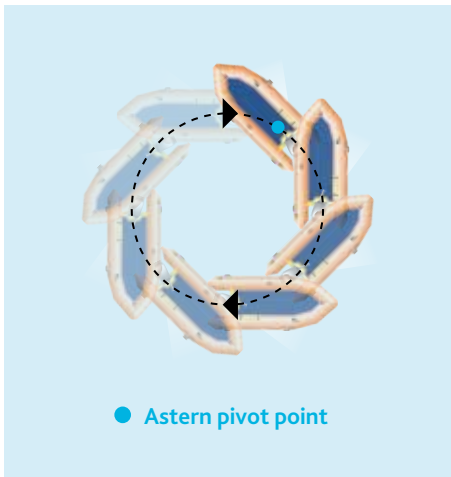
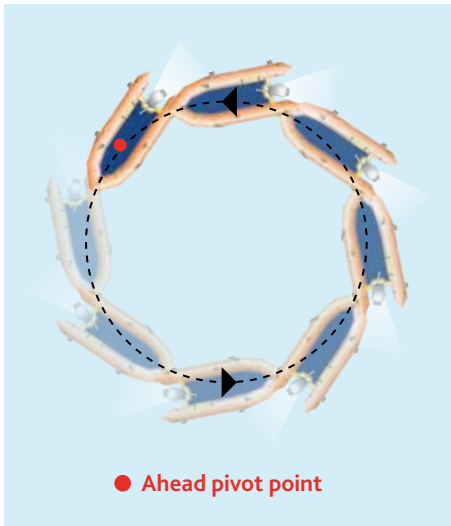

8.4 Factors affecting boathandling

Wind

Boats will drift downwind and naturally lie at right angles to the wind or with their bow slightly downwind.

The speed that this will happen depends on the amount of wind and type of boat.

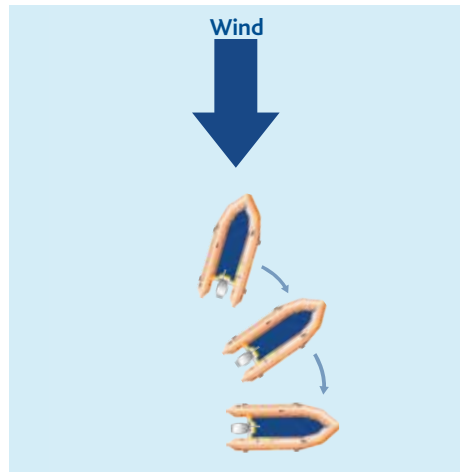

Tide/current

We can use the tide/current to help us manoeuvre the boat in a controlled manner.

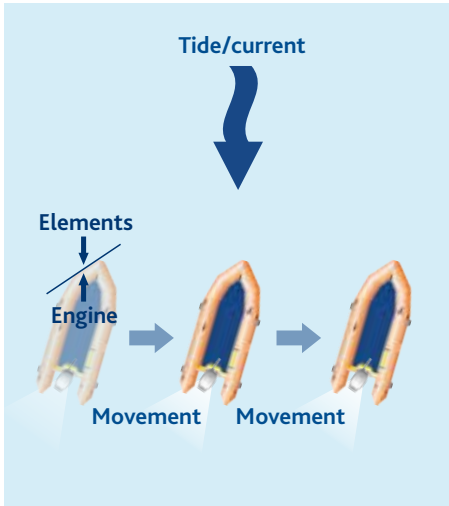

This will also work if the stern is placed into the tide/wind. This is a very effective technique to get into some tight berths.

8.5 Boat handling in heavy weather

High winds and powerful waves increase the risk in maritime SAR situations. Care must be taken when manoeuvring the boat in heavy weather to limit damage and prevent injury to the personnel on board. It makes deck work more dangerous with risk of injuries or man over board. Heavy weather can also present a risk to the whole boat leading to capsize, swamping or damage.

Some key recommendations are:

- Always wear appropriate PPE when working on deck or in open boats in heavy weather. Remain seated if possible. Keep handholds and stable positions when moving around. Consider slowing down and the use of lifelines if work has to be done on deck. Let someone know when you are going on deck and preferably work in pairs.
- Adjust the speed to match the conditions. High speed in heavy weather can make even larger boats capsize, flip over or broach. High speed can cause the bow to bury into waves, making the boat decelerate violently. It can be faster to zig zag between the waves than going in a straight line.
- Avoid surf zones and breaking waves. Lying beam on to breaking waves can cause the boat to capsize.
- Surfing in following seas might cause the boat to lose steering and turn sideways (broaching). This leaves the boat in a vulnerable position and can potentially cause a boat to capsize.

What NOT TO DO in rough weather

The following series of diagrams illustrate the 'Pendulum Effect'. This effect is the result of a series of misjudgments made by the operator and can be described as follows:

Diagram 1

A combination of the following three factors will result in the boat flying from the top of the wave.

SPEED:

The boat is being driven too fast for the prevailing conditions.

TRIM:

Incorrect trim position selected.

WAVE:

Poor judgement of sea state.

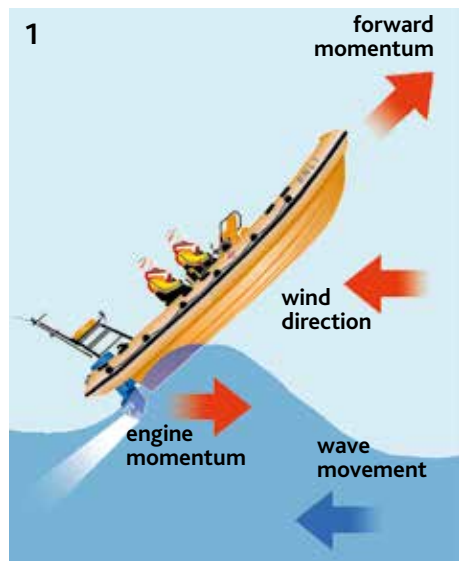

Diagram 2

Once free of the water, the boat's forward momentum will continue to lift it further into the air. The wind will act upon the hull to hold it in the air while the weight and drive of the engines will cause the stern of the boat to move faster than the bow. This is the 'Pendulum Effect'.

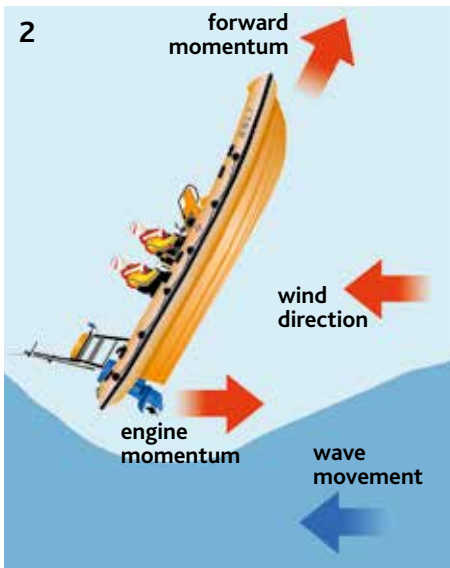
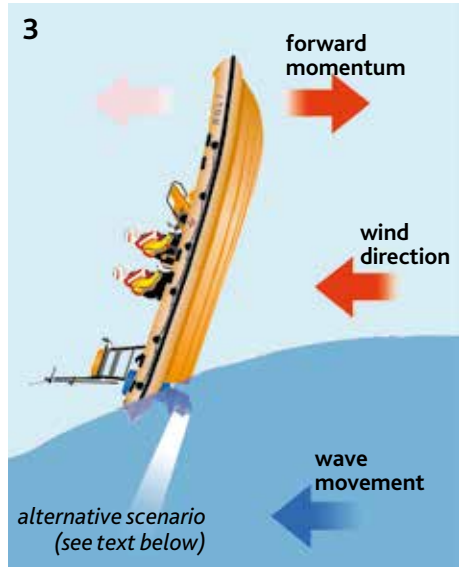

Diagram 3

The boat continues to rotate until the stern makes contact with the water. This quickly slows the stern thereby causing the bow to pivot back down into contact with the water.



Alternatively

Rotation continues until the stern actually overtakes the bow. Were this to happen the likely outcome would be that the boat would capsize bow over stern.

Unit 8: Boathandling

In an UP SEA

The following series of diagrams illustrate the correct technique for handling a boat in 'UP SEA' conditions.

Diagram 1

Prepare to "take on" the wave. Ensure the engines are trimmed IN which will help in keeping the bow down.

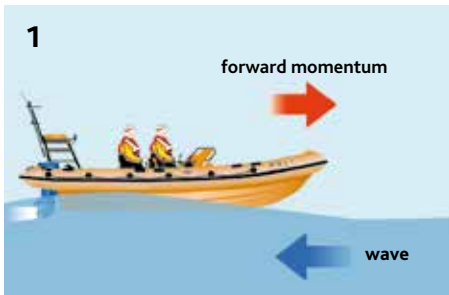

Diagram 2

Sufficient power should be applied to prevent the boat from flying from the top of, or slipping back down the face of the wave.



If the boat does fly from the top of of a wave, increase the revs to reduce the chances of stalling or swamping the engines on landing. Once landed, immediately ease off the power to prevent flying off the next approaching wave.

Diagram 3

As the wave moves beneath the boat the bow starts to drop into the following trough. Increase engine power to "soften" the landing.



Diagram 4

On landing, ease off the power and assess the alternatives for dealing with the next wave.



Alternative strategies

Turn Round: If there is sufficient sea room then turn round and "run". Be aware that in a high speed turn the engine will airate resulting in a loss of forward motion.

Alter Course: Alter course to prevent having to take on the larger section of the wave. Alter course to take on the broken water rather than the section of the wave which is about to break.

In a DOWN SEA



The diagram above shows a series of three waves. Their appearance is fairly representative of what you might expect within a typical wave set.

Things to consider before moving "down sea":

- The engines should be trimmed LEVEL (or slightly out) which will help in raising the bow.
- Choose the wave on which to position the boat.

On the diagram this is represented by wave 2 and is chosen because:

- It is the largest wave and therefore affords the greatest height of eye.
- As it is the largest wave it presents the greatest danger. By keeping it beneath the boat, it gives you a degree of control. The operator should "ride" the wave to ensure the boat does not overtake, or slide back down the wave.
- The largest wave will take the boat further up the beach in the event of an emergency beaching.
- If you are on the largest wave it is then likely that the next large wave, when you consider typical wave sets, will be further behind you.

Unit 8: Boathandling

In an ACROSS SEA.

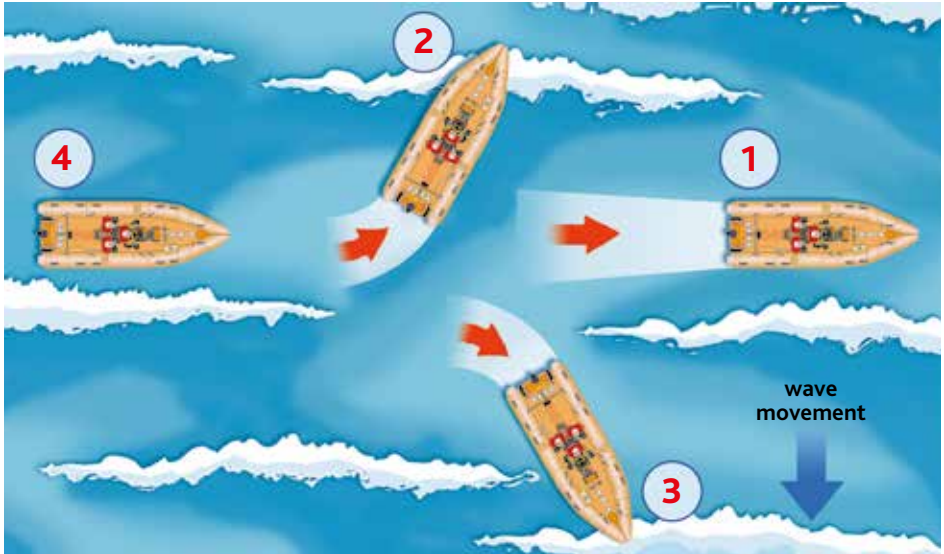

The diagram above shows four options for moving across sea.

Things to consider before moving "across sea":

- The engines should be trimmed LEVEL, this being the best set up to deal with variable sea conditions.
- **OPTION 1:** Use the boat's speed and manoeuvrability to out-accelerate the wave. To use this option it will be necessary to have sufficient reserve power available to react quickly to changing conditions.
- **OPTION 2:** Turn through 90 degrees and take the wave on. (Refer to "UP SEA" described earlier.)
- **OPTION 3:** Turn through 90 degrees and go down sea. (Refer to "DOWN SEA" described earlier.)
- **OPTION 4:** Slow down and let the wave pass in front of the boat .

8.6 Approaching other vessels at sea

Approaching other vessels at sea/transfers

As a rescue boat operator you should take real care when approaching other vessels at sea. There are a number of factors that can come into play and you should consider some of the following:

- Is there a clear reason for coming alongside the other vessel?
- What are the environmental conditions, such as sea state, weather and visibility?
- What are you transferring, equipment or people?
- Access points, such as boarding ladders, gates and rails?
- Will it be a static transfer or carried out at slow speed?

Any vessel that makes way through the water will create a bow and stern wash. Some create a mid-wash. Depending upon vessel length they may also create a series of small waves along its length.

The physical attributes of this wash create positive and negative pressure zones. A positive zone will push your vessel away, whereas a negative zone will attract you to the other vessel.

This effect is called 'vessel interaction' and when a rescue boat operator is approaching another vessel they should take this effect into consideration.

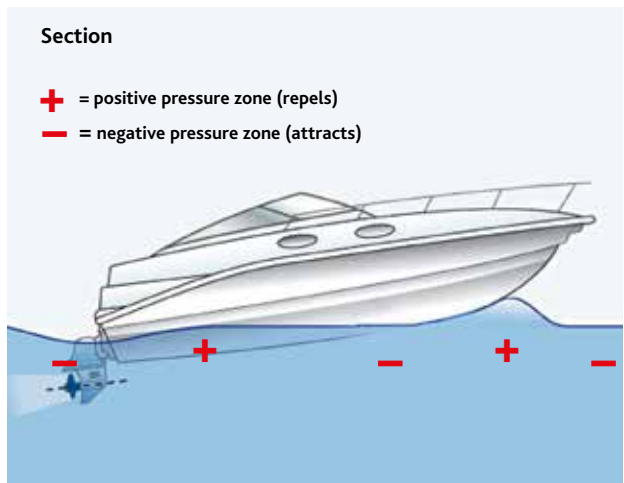
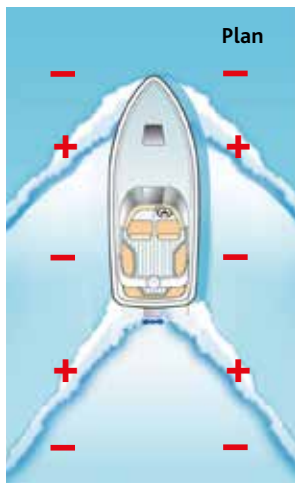

Unit 8: Boathandling



If doing a transfer whilst both vessels are moving it is recommended this is done at the minimum speed to maintain steerage. Six knots is usually a safe speed.

Ensure both vessels have communicated with each other and agree on the plan. Ensure you have clear lines of communication.

Consider deploying fenders, however if fenders are on both vessels take care that they do not become tangled.

Step 1



Approach in the negative zone paralleling your course with the other vessel's course. Where apparent use the mid wash as an approach line and it will also act as a brake. Remember when approaching the vessel aim for boarding ladder, gate, point of embarkation

Step 2



As you approach be prepared for the effect of the 'interaction' between the two vessels. Do not overcompensate for this effect.

Step 3



Once you are in the 'safe water' continue your parallel approach. Do not at this stage throw the helm over and collide with the vessel. Once the beam of your vessel is touching the target vessel lean the shoulder onto the hull using approximately 5 degrees of helm. Appropriate throttle should be applied depending which vessel you are on-board.

When exiting, reverse the above taking care not to shut the throttle off or you could enter the negative pressure zone to the stern. Gradually create a 2 – 3ft gap.

If working alongside larger vessels you find that you get pinned alongside you may have to ask the other vessel to turn towards you to open a gap allowing you to depart.

Be aware if transferring stretchers at sea for training purposes; do not use live casualties to practice this.

8.7 Mooring

Mooring to a buoy

A mooring buoy is attached to the seabed by chains, anchors or weights, to which a boat can be secured.

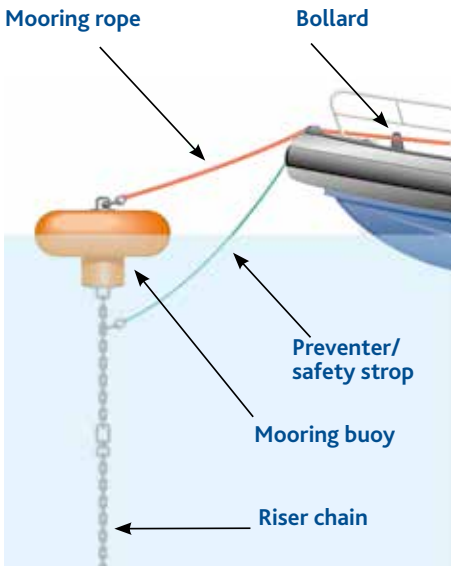

Approach

Approach the buoy slowly, facing into the wind/tide. Using small amounts of forward and neutral gear, manoeuvre up to the buoy and tie up.

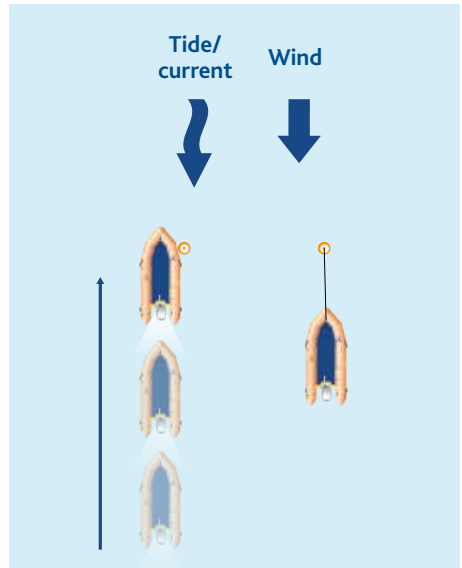

- Make sure that you have briefed your crew and have them ready with the lines.

8.8 Berthing

There are several things to consider when berthing:

- rise and fall of tides
- direction and strength of wind and tide
- depth of water (study charts/depth sounder)
- proximity of other boats
- suitability of berth/mooring to your boat
- hazards.

Stern/bow lines

- These stop the stern/bow coming away.

Springs

- These stop the boat from moving forwards and backwards.

Breasting lines

- These are additional lines to hold the boat closer if needed.

Note: in some cases you may have to account for the rise and fall of the tide by adjusting the length of the lines.

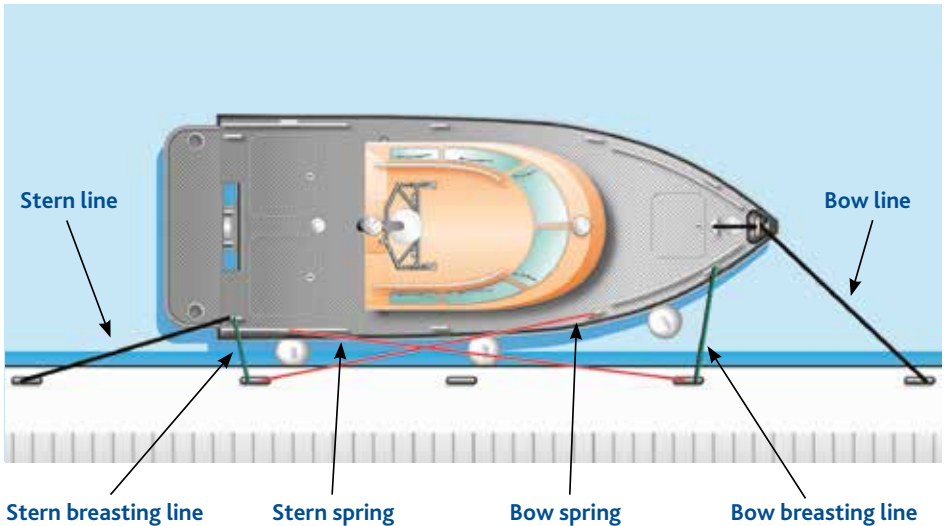

Approach

- Approach at slow speed with an angle of approximately 30°.
- As you get closer turn away in neutral, then if needed apply forward gear.
- To stop and bring the boat parallel, steer towards and use a small amount of reverse gear.

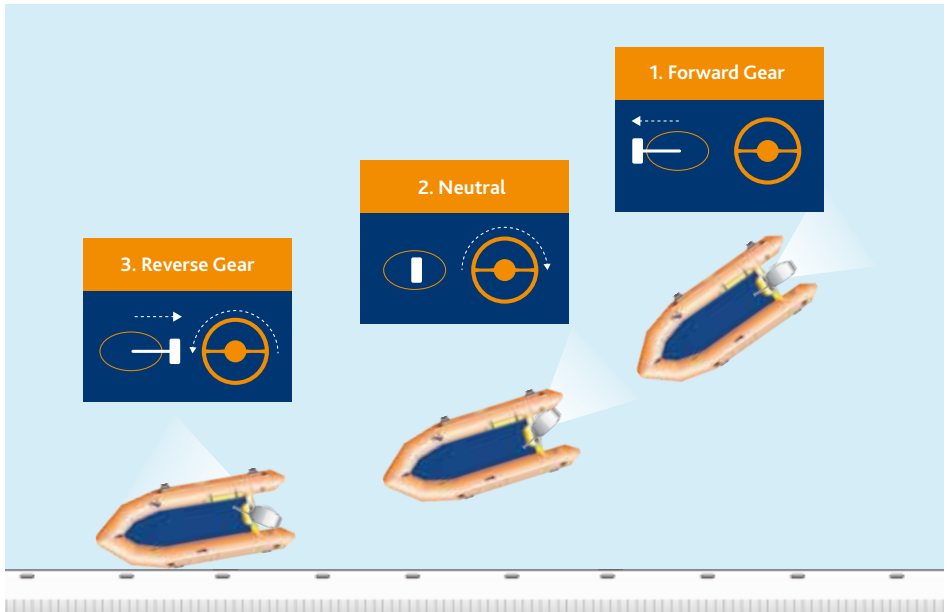

8.9 Beaching

There may be times where a rescue boat is required to beach. Beaching a boat refers to driving it towards the shoreline until it comes to a stop in shallow water due to the contact between the hull and the sand. You may have to beach the boat in order to remove a casualty or to recover the boat onto a trailer.

Be aware that beaching a boat can be dangerous, only perform this activity if absolutely necessary.

Factors to consider

Prior to beaching a boat, the helm should consider the following:

- underwater hazards, such as rocks, anchors or fishing gear
- the gradient of the beach
- other water users
- positioning onboard the boat
- wave patterns.

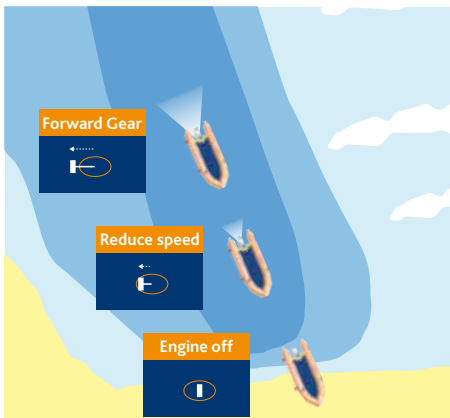

Approach speed and positioning

Before beaching, the helm will inform everyone of their intentions. This allows them to brace themselves during beaching. The helm should use sufficient throttle control in order to maintain momentum and steerage through shallow water and onto the beach.

At an appropriate time before the hull makes contact with the beach, the engine(s) should be switched off and lifted (where possible). The momentum of the boat will allow it to glide up the beach until it comes to a stop.

Prior to getting out of the boat, the crew should check for any tidal surges (waves) that may cause the boat to move.



8.10 Anchoring

Definition

An anchor is a piece of equipment on the boat that is attached to a length of chain or warp, sometimes both. When in shallow water it allows you to temporarily maintain the boat's position.

Reasons for anchoring

A boat may need to anchor:

- to take shelter or lie up in restricted visibility
- in an emergency to protect the boat, for example, with an equipment failure
- to save a boat from drifting
- if you want to leave the boat.



Types of anchor

Anchors vary in size, design and weight. Some of the more common types of anchor include:



Plough or CQR



Danforth



Bruce



Delta



Grapnel



Fisherman's

How an anchor works

The anchor lies flat on the seabed until the boat pulls on the anchor warp. This then drags the anchor along the seabed, which helps it dig itself in.

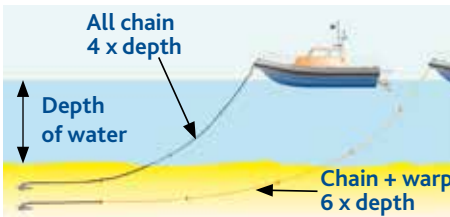

- The amount of chain used should be at least 4 times the depth of water.
- The amount of chain and warp used should be at least 4–6 times the depth of water.



To check the anchor is holding, use two fixed points to form a transit. If A and B move towards or away from each other, the anchor is not holding.

If the anchor drags, more cable should be used, or reset the anchor in a different place.

It is important to remember that wind and tide affect a boat's position when at anchor, and that these can change without warning.

Before anchoring it is essential that a **safety swinging circle** can be established.

The swinging circle (or swinging room) is the distance a boat can move around its anchor. Swinging room is important because if other boats or objects are within a boat's swinging circle they may collide.

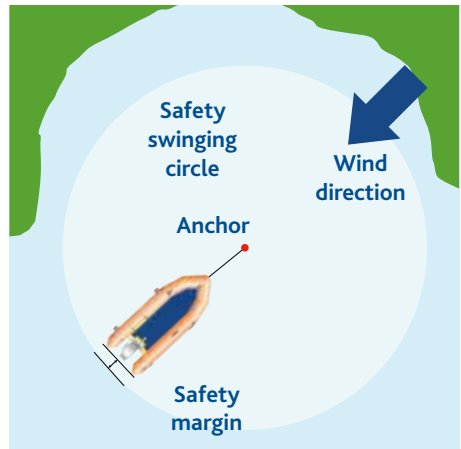

Factors to consider prior to anchoring

Before anchoring the boat, the skipper should take the following factors into consideration prior to deploying the anchor:

- the strength and direction of the wind in order to choose a location that offers the best protection
- the depth of water and rise and fall of the tide in order to allow safe under-keel clearance (if required)
- proximity to hazards, such as other boats, cliffs or underwater hazards
- the type of seabed.

A series of horizontal dotted lines spanning the width of the page, intended for writing notes.

A series of horizontal dotted lines for writing notes.



Learning outcomes

- 9.1 Be able to recover a man overboard.
- 9.2 Know the methods to recover a person onboard.
Be able to recover a person onboard.

9.1 Man overboard

If someone falls overboard, the following points should be carried out if possible:

- Shout loudly 'man overboard'.
- If possible, throw a lifering to them. Even with a lifejacket on, extra buoyancy may help/comfort them.
- One of the rescuers should look and point at the man overboard (MOB) until they have been recovered.

- Press the MOB button on the GPS/chart plotter (if there is one) – it may help in locating the casualty.
- Send a Digital Select Calling (DSC) distress alert and mayday. It is better to stand-down rescue assets than launch them to a far more serious situation later. You can never be 100% sure it will go perfectly.
- Assess the wind and decide on the direction of approach.

Approaching a person in the water

There are two main methods to approach a man overboard.

Method 1 – Into the wind

1. Reduce speed gradually and assess the conditions.
2. Position the boat six boat lengths downwind/down sea of the MOB.
3. Approach the MOB at minimum speed. Brief the rescuers which side you intend to recover the MOB.
4. Once you have reached the MOB, if conditions allow and it is safe to do so, switch off the engine and recover them.

Advantages

- Suits smaller boats with low freeboard and good access forward.
- Allows waves to be taken head on.

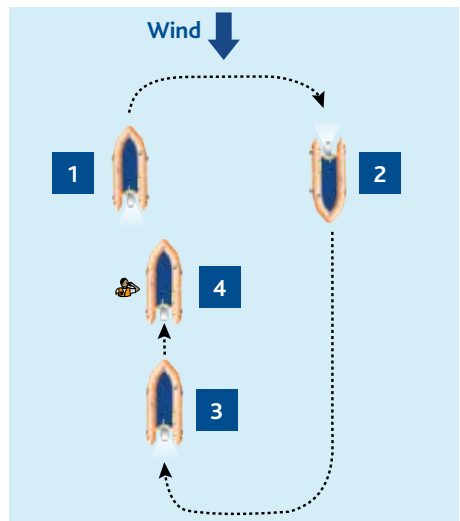

Disadvantages

- If the helm misjudges the approach, this could lead to the MOB going under the bow and result in injury.
- A higher bow limits the ability to reach and see the MOB over the final few metres.
- The helm needs to drive the boat until the casualty is reached.

Unit 9: Person in the water

Method 2 – Drift-down approach

1. Reduce speed gradually and assess the conditions.
2. Position the boat beam to the wind, upwind of the MOB.
3. While drifting down to the MOB, maintain the boat's line using small amounts of forward and reverse gear. Position the crew ready to recover the MOB.
4. Once the boat is in this position, contact can be made with the MOB and recovery can take place. If conditions allow, and it is safe to do so, switch off the engine.

Advantages

- Suits boats with a high bow with limited forward access.
- The whole of the side of the boat provides a larger target/collection area.
- Provides some shelter to the MOB.
- Allows more time for preparation such as use of VHF and recovery equipment.

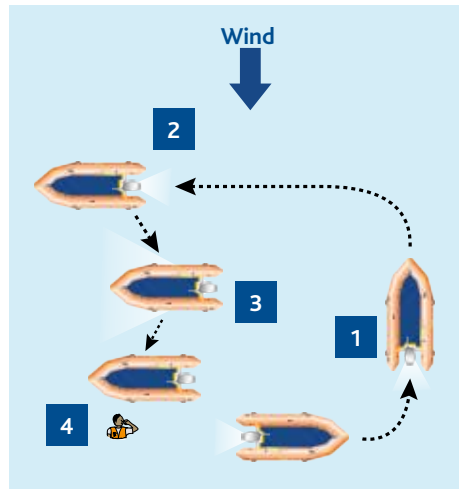

Disadvantages

- Being beam-on to waves can be uncomfortable and in large breaking seas, dangerous.
- Requires wind to drift down.

9.2 Person recovery

Should you end up in the water, ensure you are familiar with different methods of how to recover yourself back onto your particular boat. Practise this on a regular basis.



If necessary, try to create a 'step' to help you climb out of the water and into the boat.

When recovering a casualty onboard, it is important to ensure that we reduce the risk of injury to rescuers through appropriate manual-handling techniques and positioning.

Utilising the lowest deck point to the water surface, the rescuer should keep themselves low with a minimum of three points of contact with the boat, wherever possible.

The following images are some example options for recovering a casualty. Ensure that you are familiar by regularly practising the recovery methods specific to your boat.



Facing towards the sponson



Facing away from the sponson

NOTE

It is important that you regularly practice person recovery drills to ensure crews are familiar with the various methods and procedures.

Other methods of recovery

Make sure you are familiar with the different methods of recovery on your boat. It is recommended that you practice these on a regular basis.



A casualty hoist



A Jason's cradle



A boarding ladder



A Dacon rescue scoop

Lined area for taking notes, consisting of 30 horizontal dotted lines.



Learning outcomes

- 10.1 Understand the considerations to take into account before towing other boats.
- 10.2 Be able to set up an astern tow.
- 10.3 Be able to set up an alongside tow.

10.1 Factors to consider when setting up a tow

Towing, by its very nature, is a hazardous operation. It requires a high level of seamanship from all involved. Each situation will present a different set of circumstances. It is important that risk versus benefit principles are applied prior to deciding to set up a tow.

Prior to towing the following needs to be considered:

- weather
- sea state
- water depth
- boat size and condition
- number of people onboard
- is towing the best option?
- should all persons be removed and the casualty boat left?

Setting up a tow

When setting up a tow, it is important to be aware of the different types of tows available.

10.2 Astern tow

An astern tow is used in open water when towing a disabled boat behind the rescue boat.

Crossing the 'T' approach

Crossing the 'T' is if the casualty boat sits beam to wind.

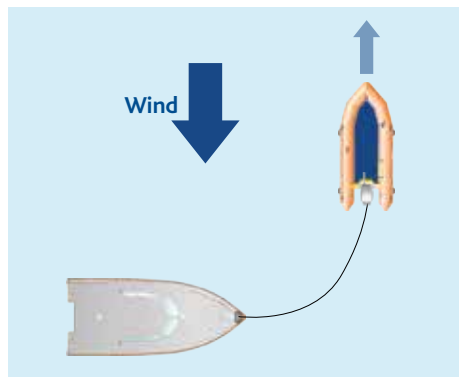
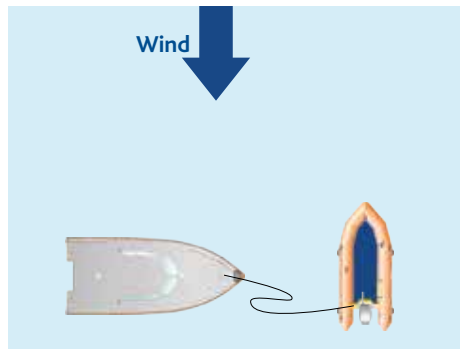
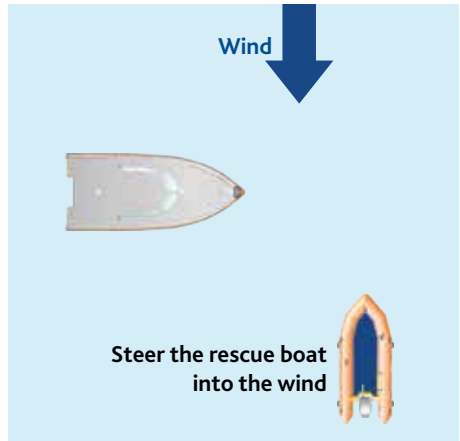

Head to Sea approach

Boats are usually head to sea because they could be anchored or attached to a mooring buoy.

The helm advises the crew on which side the tow is to be rigged and passed to the casualty.

The helm approaches the casualty and the crew passes the tow line as early as is practicable.

The helm positions the lifeboat a short distance from the casualty boat, but does not continue to drive away. This will allow the crew member time to secure the tow line.

The crew member on board, having caught the tow line, passes it under any stanchions and through the fairlead of the boat. The line must be secured to a strong point on the boat. Once secure, the helm slowly takes up the tow.

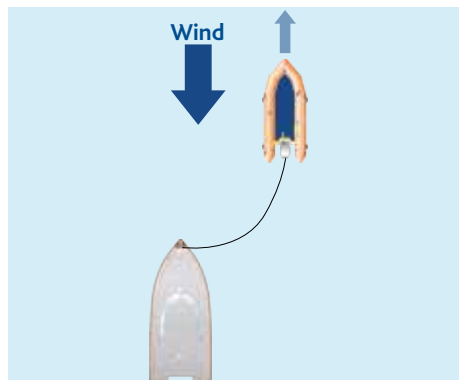

Onboard the casualty boat

Pass the tow rope to the bow of the broken-down boat and ask the people onboard to secure the rope to the boat.

Make sure that the tow rope is secured to strong points on the boat. These strong points need to be secure within the structure of the boat.

Where possible, tie the rope to several strong points to share the load.



Key points:

- In rougher conditions make the tow as long as possible while matching the wave phase.
- Weighting the tow rope will reduce snatch loading.
- It is important to be able to change the length of the tow rope, for example, when entering a harbour entrance or to minimise chafe.



WARNING

Be aware of the limitations of your boat when towing a larger vessel.

10.3 Alongside tow

An alongside tow is used when space is limited, for example, when entering harbours, marinas or small entrances. This gives the helm the ability to manoeuvre both the rescue boat and casualty boat with more control within a confined space.

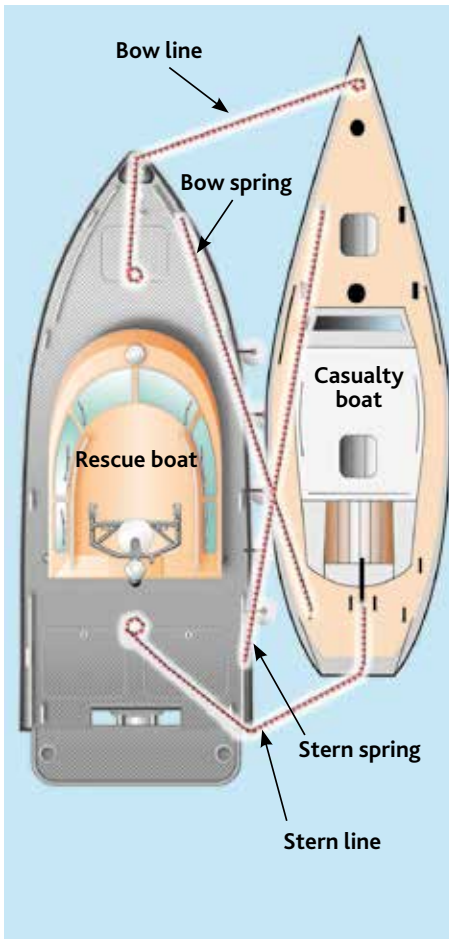
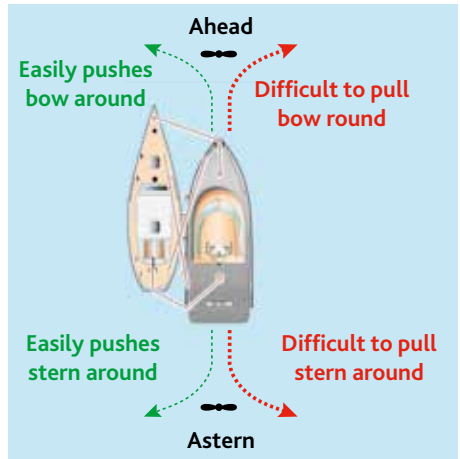

WARNING

If you are towing a vessel that is aground, be aware that this could lead to further damage and flooding to the casualty vessel. Only tow if absolutely necessary.

Unit 11: Distress and communication



Learning outcomes

- 11.1 Understand the different type of distress signals.
- 11.2 Understand the different methods of radio communication.

11.1 Distress signals

There are a number of international ways of notifying others that you are in distress. They can be categorised as follows:

- physically
- sound and light
- flags and shapes
- electronically
- radio and telephone
- pyrotechnics (flares).

Physically



The slow and repeated raising and lowering of the arms.

Fire



Burning oil in a barrel onboard can be a way to send a distress signal.

Sound and light

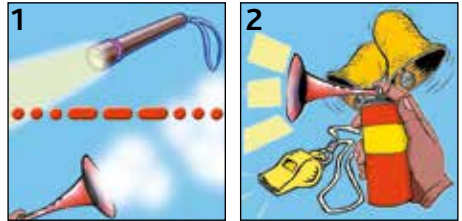

1. SOS sent in morse by any means - sound or light.
2. A continuous sounding fog horn, bell or whistle. A gun or other explosive device fired at intervals of about a minute.

Flags and shapes

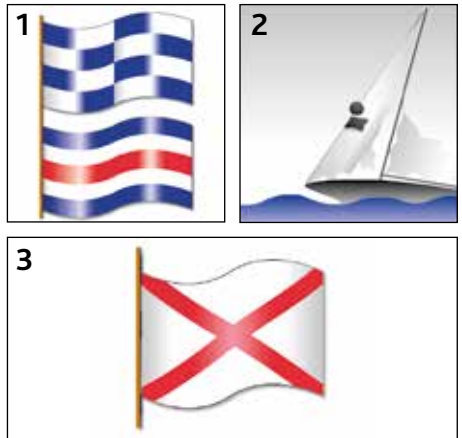

1. The flag N-ovember arranged above the flag C-harlie as shown. (This is the International Code Signal of distress.)
2. A square placed above or below a ball (or anything resembling a ball).
3. Although not strictly a distress signal the Victor Flag does indicate that a vessel is in need of assistance.

Pyrotechnics



Distress flares

A flare pack should be carried and can be used when in distress. The amount and type of flares needed vary depending on the operating area of the boat. Do not use parachute/rocket flares near helicopters!

Electronic distress signals

Emergency Position Indicating Radio Beacon (EPIRB)



The EPIRB must be registered with the appropriate authorities. It is registered to an individual boat and is stowed on deck to be released manually or automatically.

When activated it sends a distress signal to a ground station via a satellite system pinpointing the position of the stricken vessel.

Possible drawbacks to the EPIRB are accidental activation and being sold to a different boat and not being re-registered.

Search and Rescue Transponder (SART)



A SART shows your position on another boat's radar. It reacts to radar by showing up as a series of 'radar blips' on the bearing of the casualty vessel.

As it gets closer to the casualty vessel, the more complete the rings become on the rescue vessel's radar.

Eventually the radar rings form a complete circle when the rescue vessel is approximately 1 mile from the casualty.

Automatic Identification System (AIS)



The automated identification system transmits data on VHF channels 87 and 88. An AIS SART is able to float and incorporates an onboard GPS that will transmit positional data every minute. Only vessels and shore stations fitted with an AIS receiver will be able to detect an AIS SART.

Checks: AIS transponders should be installed as specified by the manufacturer.

Developments: As well as updatable positional information, the AIS SART has a unique MMSI number that starts with 970 followed by six numbers making a nine-digit MMSI number (for example; 970991234). The AIS SART will be deployed similar to the radar SART.

An AIS receiver will display a red circle with a cross in it when the AIS transponder is activated.

Personal Locator Beacon (PLB)

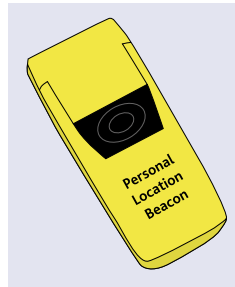

A PLB is an electronic aid to location, which can be activated when in a distress situation, alerting the rescue authority of your position.

11.2 Radio communications



Communication equipment is going to be a vital part of providing search and rescue. It should be able to provide a two-way communication between both the MRCC and the rescue boat and also with the persons in distress.



CHANNEL 16

VHF Voice Call

VHF radio/telephone - distress call

The VHF radio is used to alert the coastguard, and other vessels in the area, to an emergency situation.

The VHF radio is better than a mobile phone for distress calling as other vessels in the area, rescue boats and helicopters will be able to hear and contact the casualty.

Note: Anyone can make a distress call. It is one of the few circumstances where you do not require a radio operator's certificate to operate the VHF radio.



CHANNEL 70

Radio Distress Alert

Digital Selective Calling (DSC) - Distress Alert

The DSC is a radio system which transmits a digital distress message on channel 70. It is activated by pressing and holding down the Distress button. This represents an "undesigned" DSC distress alert.

If time permits, a "designated" distress alert may be sent which alerts listeners to the type of emergency taking place (i.e. fire, sinking etc).

A DSC Distress Alert must be followed by a distress VHF radio voice call.

The “MAYDAY” distress call

A Distress Alert is an open broadcast radio call with the top priority rating.

It is a transmission made when:

“A vessel, aircraft, vehicle or person is threatened by grave and imminent danger and requires immediate assistance.”

The word ‘Mayday’ comes from the french ‘m’aidez - meaning ‘assist me!

The format of a Mayday call is always as follows:

- M** • MAYDAY repeated three times
- I** • Identification repeated three times
- R** • Repeat MAYDAY and identification once only
- P** • Position - latitude and longitude or range and bearing from a known position
- D** • Distress, nature of
- A** • Assistance required
- N** • Number of persons on board
- I** • Information
- O** • Over

The “PAN-PAN” urgency call

PAN-PAN urgency call is the International standard urgency call signal that someone aboard a ship, aircraft, or other vehicle uses to declare that they have a situation that is urgent but, for the time being at least, does not pose an immediate danger to anyone’s life or to the vessel itself. This is referred to as a state of urgency. This is distinct from a mayday call (distress signal), which means that there is imminent danger to life or to the continued viability of the vessel itself. Radioing pan-pan informs potential rescuers (including emergency services and other craft in the area) that an urgent problem exists, whereas mayday calls on them to drop all other activities and immediately begin a rescue.

The format of a Pan-Pan call is as follows:

- P** • Pan-Pan repeated three times
- A** • All stations repeated three times
- I** • Identification repeated three times
- P** • Position - latitude and longitude or range and bearing from a known position
- I** • Information
- O** • Over

All messages concerning a distress alert must start with the word ‘MAYDAY’

Direction Finding (DF)



VHF DF and UHF DF (direction finding) equipment can also be fitted to the rescue boat and can be an asset to locating the person in distress.

Telephone



Mobile phones

It must be stressed that although a mobile phone may be used as a means of notifying others of an emergency situation, it should only ever be considered as a secondary device. Using a mobile phone has several limitations:

Battery life:

When relying on battery power alone, the availability of service may become unreliable. A problem could arise part-way through a distress call if the phone's battery were to lose its charge.

One-way communication:

A mobile phone only offers one-way communication and does not allow rescue vessels to listen in on the conversation between casualty and coastguard. Also, the mobile phone's radio wave frequency cannot be used with Directional Finding (DF) equipment.

Waterproofing:

Generally, even the "waterproof" phones suffer in a salt water environment.

Service area:

The area coverage of the service providers has increased to cover most of the channel, but this cannot be guaranteed for all service providers.

A series of 25 horizontal dotted lines for writing notes.

A series of horizontal dotted lines for writing notes, spanning the width of the page.

Unit 12: Search and rescue (SAR) information and planning



Learning outcomes

- 12.1 Understand risk versus benefit.
- 12.2 Understand the abbreviations used in searching.
- 12.3 Know the process and information needed to respond to search and rescue (SAR).
- 12.4 Know the two main types of searches.
- 12.5 Understand how to set up a search
- 12.6 Understand how carry out an expanding square search
- 12.7 Understand how to carry out a sector search
- 12.8 Understand how to carry out area searches
- 12.9 Understand the rapid response method
- 12.10 Understand different types of search techniques

Unit 12: Search and rescue (SAR) information and planning

12.1 Risk versus benefit

Before undertaking a rescue the rescuer must decide whether the risk to the rescuers is worth the likelihood of a successful rescue.

When rescuing a casualty, your priorities are:

1. You
2. Crew
3. Boat
4. Casualty.

The rescuer should:

- take account of the hazards and potential risks when considering a rescue
- develop a plan that minimises the risk to both rescuers and casualties.

The chart should be used to plot the level of risk, from low to high on the vertical axis. The degree of benefit to be gained from effecting a successful rescue should be plotted from low to high on the horizontal axis.

This process can be completed as a mental model before a rescue, and re-evaluated during the rescue.

- Consider other options such as:

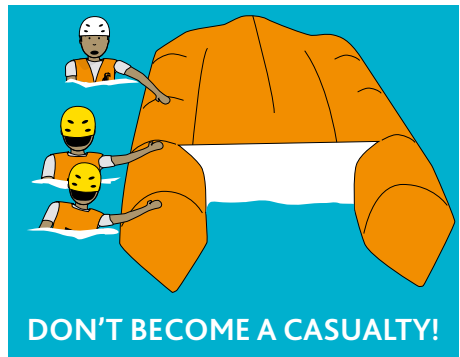
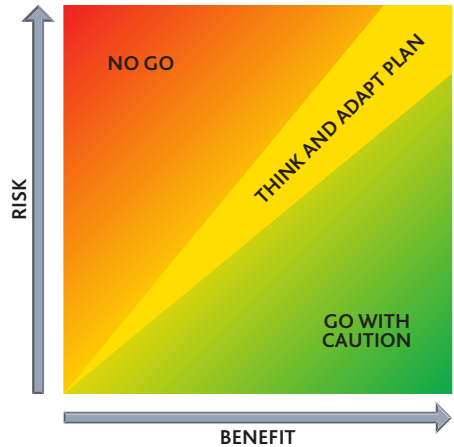

12.2 Search abbreviations

There are some terms that you need to be familiar with:

- **MRCC – Maritime Rescue Co-ordination Centre**
Responsible for co-ordinating the conduct of maritime search and rescue operations within a search and rescue region.
- **SRU – Search and rescue unit**
A unit of trained personnel who are provided with equipment suitable for search and rescue operations.
- **SMC – Search mission coordinator**
The official who is temporarily assigned to coordinate the response to an actual or apparent distress situation.
- **CSP – Commence search position**
This is the position, normally specified by the search mission coordinator, where the search and rescue unit is due to start its search.
- **OSC – On-scene coordinator**
A person designated to coordinate search and rescue operations within a specified area.
- **MRO – Mass Rescue Operation**
Search and rescue services characterized by the need for immediate response to large numbers of persons in distress, such that the capabilities normally available to search and rescue authorities are inadequate.

12.3 Tasking process

You can use RAPEL to help with search and rescue:

Record

Assess

Plan

Execute

Learn

1. **R**ecord the information you are given about the search and rescue you are being tasked to.
2. **A**ssess this information to work out what you will do.
3. **P**lan – Based on the information you can then start to formulate a plan.
4. **E**xecute – Once you have formulated your plan you can then execute it. Sometimes it may be necessary to change the plan based on new information.
5. **L**earn – Always remember to have a debrief after the incident. Bring out any learning points.

SMEAC Brief

It is important that all crew are aware of the situation and any other information that may be relevant to them. This information can be given to the crew in the form of a SMEAC brief.

Unit 12: Search and rescue (SAR) information and planning

Below is a blank template for a SMEAC brief.

SITUATION <ul style="list-style-type: none">• Ground:• Hazards:• Weather:• Tide:• Other agencies:• Event:		S
MISSION <ul style="list-style-type: none">• Our mission is:• In order to:		M
EXECUTION <ul style="list-style-type: none">• General outline:• Grouping/tasks:• Emergency plan:		E
ADMINISTRATION <ul style="list-style-type: none">• Dress:• Equipment:• Food/water:• Medical:• Transport:• Casualty routine/evacuation:		A
COMMAND AND COMMUNICATION <ul style="list-style-type: none">• Type:• Call signs:• Lost comms:• Frequency/talkgroup:• Ops normal:• Confirmation of understanding• Questions:		C

12.4 Types of searches

Each search pattern has a specific use. Some are better suited for small, confined areas, while others are better suited to larger areas.

Regardless of the type of search pattern selected, you are expected to understand the Search Mission Coordinator's (SMC) Search Action Plan (SAP) and be able to complete the assigned search. Once the SMC determines the search area, a systematic search for the object must be planned.

The SMC will consider weather, search area size, search object size, numbers of Search and Rescue Units (SRUs) available, search area location, and time limitations in deciding which pattern to use

You may be asked to carry out two types of searches. These can be a datum or an area search. Which search you undertake will be determined by:

- timescale
- accuracy of information.

Datum search

A datum is a geographic point, line or area used as a reference in search planning. A datum position is the most probable position of the casualty with the information available.

Datum searches are water based.

- The area covered by the search moves as the search boat and casualty are affected by tide or wind.
- They rely on there being a good initial datum – a distinct start point for the search.

- Only use the steering compass for heading. Do not use course over ground (COG) and do not pick a point on the shore to steer to. As the search is a water search, the search area must be allowed to move due to tide/wind.

There are two types of datum searches:

- Expanding square search
- Sector search

Area search

Area searches are used when the information is dated or less accurate and where there are many possibilities of where the casualty could be. They are calculated using:

- up-to-date tide information
- wind strength and direction to calculate the leeway (wind drift) of the casualty
- wind information from the last 24 hours to establish wind-driven current.

There are several types of area searches:

- Parallel track search
- Creeping line ahead search
- Ammended creeping line ahead search
- Track line search
- Barrier search
- Line abreast search

NOTE

During a search you should take into account your coastal geography and also the use of your local knowledge.

Unit 12: Search and rescue (SAR) information and planning

12.5 Setting up a search

The search pattern and track spacing should be given to the SAR Unit by the MRCC. However, when setting up a search and based on the weather on scene, you may be required to work out the sweep width and track spacing as part of your search plan.

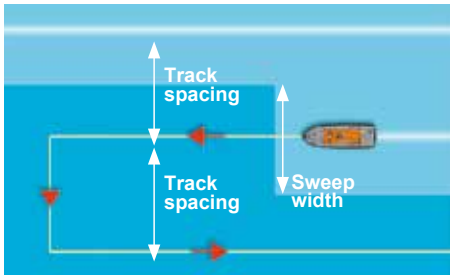

To work out the sweep width, use the following table:

		WIND SPEED / SEA STATE ON-SCENE		
		<16kts / <0.6m Sea	16-25kts / 0.6m-1.2m	>25kts / >1.2m Sea
		ASSUMED SPEEDS		
TARGET TYPE		20 knots	12 knots	8 knots
	PERSON IN WATER	SWEEP WIDTHS		
	Visibility <3NM	30secs (0.17 nm)	30secs (0.10 nm)	30secs (0.07 nm)
	LIFERAFT			
	Visibility 1NM	2mins 30secs (0.83 nm)	2mins (0.40 nm)	1min 30secs (0.20 nm)
	Visibility 3NM	6mins (2.00 nm)	5mins (1.00 nm)	3mins 45secs (0.50 nm)
	Visibility 5NM	8mins (2.66 nm)	6mins 45secs (1.35 nm)	5mins (0.67 nm)
	POWER AND MFV <5m			
	Visibility 1NM	1min 15secs (0.42 nm)	1min (0.20 nm)	45secs (0.10 nm)
	Visibility 3NM	2mins 30secs (0.83 nm)	2mins (0.40 nm)	1min 30secs (0.20 nm)
	POWER & MFV 5m-15m			
	Visibility 1NM	2mins 30secs (0.83 nm)	2mins (0.40 nm)	1min 30secs (0.20 nm)
		ASSUMED SPEED		
TARGET TYPE		10 knots		
	PERSON IN WATER	SWEEP WIDTH		
	Visibility <3NM	60secs (0.17 nm)		

Sweep width

This is how far the crew look either side of the boat. Sweep width is the distance either side of the boat, added together, that the casualty can be expected to be spotted.

Track spacing

The track spacing is the distance between each track the rescue boat takes and is equal to sweep width. Speed and track spacing should be consistent and appropriate to the conditions, scenario and size of rescue boat.

Unit 12: Search and rescue (SAR) information and planning

12.6 Expanding square search

An expanding square search is best used when the casualty's position is confidently expected to be within a relatively small area. As with all datum searches the expanding square relies on a good initial datum.

As with both datum searches, it is better to only use a compass for the heading and stopwatch for timing the distance. Using a GPS or other electronic navigating system does not take into account the effect of the wind and tide on the casualty.

Preparation

- Once you know what you are searching for (person in the water, small boat, big boat), work out your speed, timings, and how far to look from the sweep width table.
- Multiply the leg timings as shown in the illustration and below.
- Decide on the appropriate initial heading.

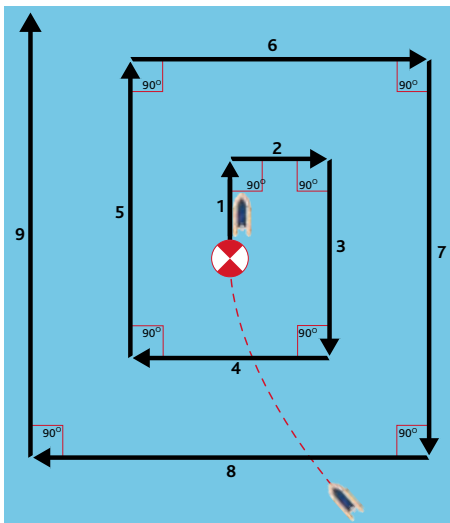

The search is conducted in legs, starting from the datum.

- Leg 1 = Track spacing
- Leg 2 = Track spacing
- Leg 3 = 2 x Track spacing
- Leg 4 = 2 x Track spacing
- Leg 5 = 3 x Track spacing
- Leg 6 = 3 x Track spacing

... and so on.

The track spacing is shown as 'S' on the illustration.

Carrying out the search

- Using the speed given in the sweep width table, set your speed on the first leg and keep this the same for all legs. Do not change this.
- Start the stopwatch and use the compass to head along the first leg for the set time. Use North, South, East and West to make steering easy.
- Ask the crew member who is monitoring the stopwatch to tell you the new course and bearing 10 seconds before making the turn.
- At the end of each leg turn 90° to starboard.
- Repeat using the required track time.

12.7 Sector search

A sector search is best used when the information about the datum is very fresh.

As with both datum searches, it is better to only use a compass for the heading and stopwatch for timing the distance. Using a GPS or other electronic navigating system does not take into the account the effect of the wind and tide on the casualty.

Preparation

- If there is no physical datum, place a fender or buoy with a line attached in the water (or something that will drift like the casualty you are looking for) to act as a datum point.
- Once you know what you are searching for (person in the water, small boat, big boat), work out your speed, timings, and how far to look from the sweep width table.

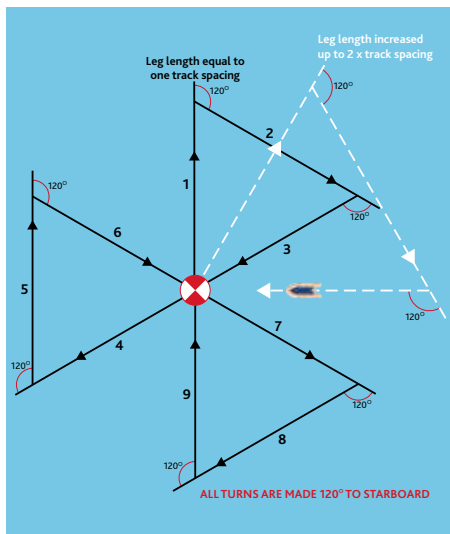

Carrying out the search

- Using the speed given in the sweep width table, set your speed on the first leg and keep this the same for all legs. If safe to do so, do not change this.
- Start the stopwatch and use the compass to head along the first leg for the set time. Use North for the first leg to make steering easier.
- The first 9 leg lengths are equal to 1 x track spacing.
- Ask the crew member who is monitoring the stopwatch to tell you the new course and bearing 10 seconds before making the turn.
- At the end of each leg, make a 120° turn to starboard.
- On leg 3, 6, and 9, look for your datum (fender/buoy) and, if necessary, adjust the direction of the boat so that you go past the datum.
- As you pass the datum, come back onto course and restart the stopwatch.
- Repeat until you have carried out three full sectors.

If there is no success after one full rotation (three triangles), increase the bearing by 30° and increase the leg length by up to 2 x track spacing.

12.8 Area searches

Parallel track and creeping line ahead

The two area searches most commonly used are the parallel track and creeping line ahead. They have the same coverage and efficiency. However one may be preferable to the other due to factors such as sea state, sun glare, moon light and the shoreline.

As with all ground-based searches electronic navigation system, such as GPS, can be used.

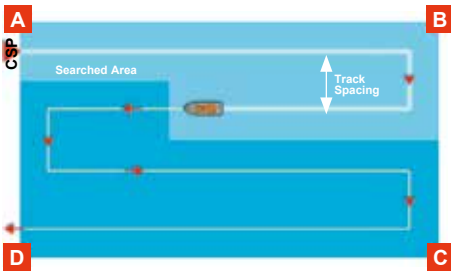

Parallel track search

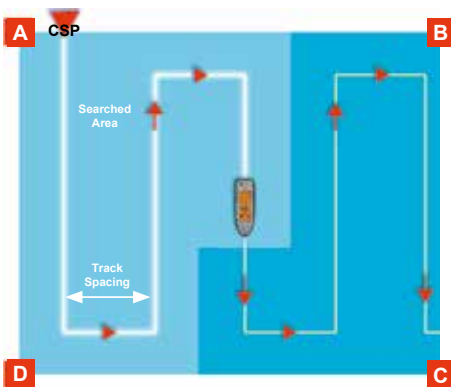

Creeping line ahead search

Preparation

- Plot the commence search position (CSP) and search legs.
- Assess and identify any hazards in the area you have been tasked to search.

Carrying out the search

- Maintain the required speed over ground (SOG).
- Maintain the required course over ground (COG).
- Travel the distance of the leg length.
- Turn 90° in the requested direction.
- Travel the track space distance.
- Turn onto the reciprocal (opposite) heading of the initial leg.
- Update the SMC of any situational changes and if you are unable to complete any of the requests.
- Maintain a lookout.
- Maintain safe navigation.

Amended creeping line ahead

This search is similar to a creeping line ahead search, and is used in river estuaries, between islands or where there are sandbanks. The length of each leg is dictated by the river or sandbanks.

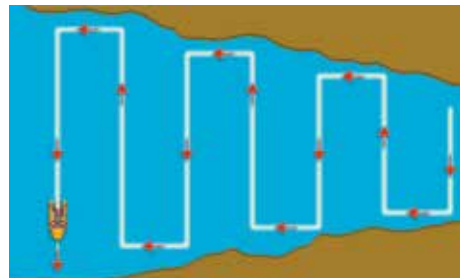

Unit 12: Search and rescue (SAR) information and planning

Barrier

Barrier searches across the tide / river for a short distance whilst the casualty is drifting towards you. This is a combination of an area and drift search.

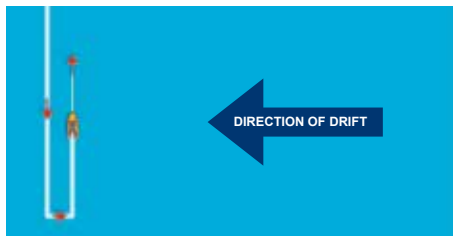

Track line

The search may be a single sweep along the length of the boat's track. If the search is to consist of two legs, then each leg would be a half of a track spacing either side of the casualty's track.

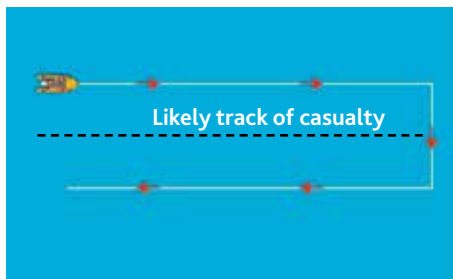

Multi-vessel

This search is based on the same principles as the single boat parallel track and creeping line ahead search pattern.

The search vessels are spaced at the required track spacing in line abreast and will generally travel at the speed of the slowest vessel.

This is a useful search pattern when using vessels that have limited navigational capability – for example, fishing boats.

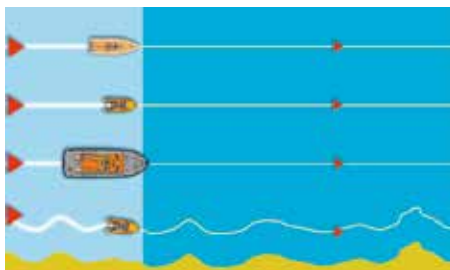

Preparation

- An appropriate person would act as OSC. It may be preferable for the OSC to place themselves on a larger vessel assisting with the search that has more suitable equipment and a working platform.
- GPS and radar can be used.
- The OSC should position the vessels in the most appropriate order considering the vessels' characteristics and crews' competency.
- Each vessel is 1 x sweep width apart.

Carrying out the search

- All vessels are to stay at the speed of the slowest vessel and stay in line.
- Travel along the first leg for the set distance.

Unit 12: Search and rescue (SAR) information and planning

Carrying out a search turn

- Radar could be used to maintain the sweep width between vessels.
- All communications to be passed through the OSC.
- If there are any potential sightings, the whole search should be paused by the OSC while they are being investigated.
- At the end of this leg, the furthest vessel from the new course turns 90°.
- The vessel passes behind and crosses the wash, then the next furthest vessel turns 90°.
- This is repeated until all the vessels have turned 90°.
- Once the last vessel to turn has travelled one track spacing, that vessel should turn 90° and continue the process until all vessels are onto the reciprocal (opposite) heading of the initial track.
- Continue this process until you have covered the search area.

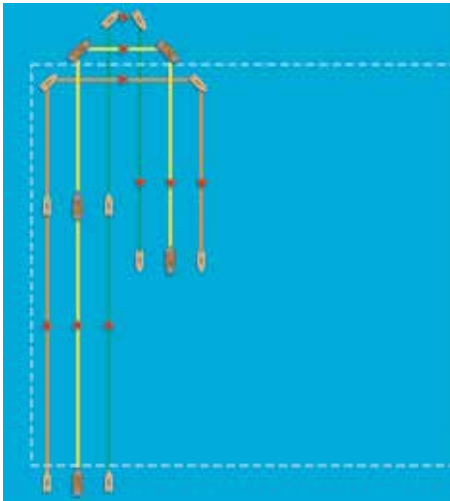

12.9 Rapid response method

The rapid response method (RRM) is a way of working out the datum and search radius.

It is generally used up to 1 hour after the incident.

You need:

- a drift start position (DSP)
- a datum time
(your estimated time of arrival or ETA)
- tidal data
- wind speed and direction
- type of casualty.

12.10 Search techniques

It is crucial that crew are looking out from the port and starboard sides of the boat in order to cover the sweep width. If this is not done, the search will be ineffective.

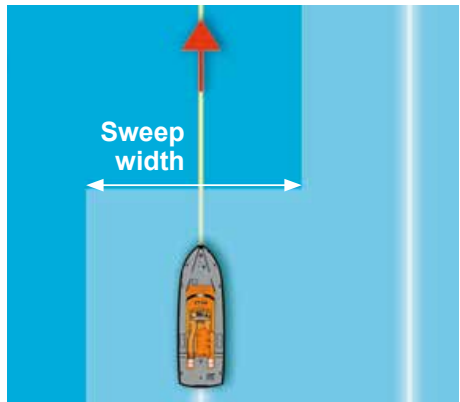

Factors that may hinder your ability to search effectively include:

- weather
- visibility
- sun glare
- casualty characteristics
- sea state
- fatigue.

Scanning techniques

It is important that crew maintain a good all-round lookout, which includes listening for sounds such as whistles or shouting.

The most effective way to search for an object using your eyes is scan–focus–scan.

To do this you need to move your head through no more than 15° while keeping your eyes centred. When you are at the end of each arc, focus before repeating.

The reason for this is so that your eyes do not get tired, thus reducing the effectiveness of the search.



Unit 12: Search and rescue (SAR) information and planning

Some equipment that could assist with these factors are listed as follows:

Searchlights

A searchlight is a very bright light source with a powerful beam of light. A searchlight may be hand-held or can be mounted to a rescue boat on a tilt-and-swivel mechanism.

The searchlight can then be pointed in the required direction. Searchlights can be powered either by a battery pack or from the rescue boat's own electrical power supply for use at night or in reduced visibility.

A searchlight has a narrow field of vision and will also affect your night vision. It may be preferable to use it only to light up distinct objects.



Binoculars

Binoculars have a narrow field of vision, they can be focused in onto a distinct object.

Binoculars should only be used when you think you can see something. Overuse can affect your ability to readjust your focus.



White parachute rocket

These can be used when there is limited background light.



Radar

The radar may be used to locate and identify casualties, assist with multi-vessel search management and provide an assessment of visibility. Note that due to the limitations of radar, not all vessels and casualties will show up clearly, if at all, particularly a person in the water.



A series of horizontal dotted lines for writing notes.



Learning outcomes

- 13.1 Know what to check for following a search and rescue mission.
Understand why recording information is necessary.
Know what information needs to be recorded.
- 13.2 Understand the importance of mental health and wellbeing.
- 13.3 Understand the level of first aid training needed.

13.1 Post-incident procedures

Following a search and rescue operation, it is important that rescuers follow the post-incident procedures in order to make their boat ready for the next rescue mission.

Debriefing

Debriefing helps us to:

- Ensure the welfare of the team after any incident, exercise or training.
- Ensure that equipment is accounted for, operationally ready and any defects reported.
- Ensure any lessons learnt from the event are recorded.
- Develop the team to improve performance at the next incident.
- Do not release any of casualty details to the media (this includes posting any information on social media).

The debrief can be structured around the following headings:

Safety

Equipment

People

Performance

Post-incident checks

- Refuel and check all engine fluid levels.
- Check the engine for damage and service if necessary.
- Check boat engine spares and ensure that any equipment used is stowed correctly.
- Replace any consumable items such as first aid equipment.



Keeping records

Recording incidents is important to measure and record success. It also helps to improve the service and identify any patterns of people getting into difficulty, as well as help to build support from local government and other agencies.

Some of the information you may be asked to gather may include:

- name and age of the casualty
- what the incident was
- where the incident was
- what assistance you provided
- other rescue organisations or boats involved.

It is important to maintain the privacy of casualty details and not release them to the media. Please be aware and adhere to local data protection laws.

13.2 Mental health and wellbeing

Team welfare

After any SAR operation, the overall welfare of the team is critically important. The rescue boat operator can play a crucial role in ensuring the physical and emotional welfare of their team or crews after an incident.

After involvement in traumatic incidents, you should be vigilant that procedures are followed to ensure crews are able to discuss the incident and to access support and counselling.

Crews should have an awareness of the signs and symptoms of stress, post-traumatic stress (PTS) and post-traumatic stress disorder (PTSD).

Stress

Acute stress reactions can occur within minutes of being involved in a stressful event. They normally disappear within 2-3 days but usually within a few hours.

They can include:

- disorientation
- confusion
- inability to comprehend instructions
- agitation
- anxiety
- withdrawing into oneself.

They are the visible signs of the brain processing traumatic information that it has suddenly received.

Post Traumatic Stress (PTS)



Sometimes, reaction to trauma can be delayed or may not subside. It is thought that the brain does not 'process' the memory in the normal way and can lead to a variety of symptoms

Symptoms of PTS include:

- recurrent dreams
- intrusive thoughts of the event
- cues that remind one of the event
- difficulty sleeping
- difficulty concentrating
- irritability or outbursts of anger
- avoidance of situations.

If left unchecked, PTS can lead to PTSD, a medical condition where disturbances become obtrusive and severely affect a person's personal and work life.

13.3 First aid

Maritime SAR organisations are often the first people on scene to help people in trouble during an incident. This can result in somebody becoming ill or injured.

First aid is basic medical care which can be administered by trained people with limited equipment. The aims of first aid are to preserve life, prevent worsening of the condition, and promote recovery of the casualty.

SAR personnel should be trained in first aid techniques and be provided with first aid equipment to use in order to deal with these situations when they arise.

Due to the variations in capabilities and legal framework this book does not cover all aspect of first aid, but rescuers should, as a minimum, understand the need and have the skills of:

- basic airway management including the recovery position
- recognizing the hazards of exposure on health (heat, cold, workload)
- Basic life support which includes Cardio Pulmonary Resuscitation (CPR).



TP-INT-05-02

Produced by RNLI Learning Resources